

User Manual – PULSAR H Single Solenoid HPA Engine

Última actualización 14 octubre, 2024 • 20 min de lectura

- [General Information](#)
- [Device Structure](#)
- [Safety Summary](#)
- [Installation of PULSAR H in the Gearbox TITAN II Bluetooth®](#)

[Introductory Information](#)

[Fitting the PULSAR H Engine in the Gearbox using the example of a replica with TITAN II Bluetooth® installed](#)

[Axial alignment](#)

- [PULSAR H Engine Maintenance](#)

[Necessary tools](#)

[Maintenance manual](#)

- [Repair Kit](#)

- [Troubleshooting](#)

[Which Hop-Up bucking should be used with the PULSAR H engine?](#)

[Which medium can I use for the power supply of the engine?](#)

[What thread for the power line?](#)

[Are there IGL lines available for the engine?](#)

[Is the PULSAR H engine close or open bolt?](#)

[How much maximum pressure can I set with the PULSAR H engine](#)

[I have a problem with low FPS](#)

[What regulators are compatible with the PULSAR H?](#)

[What to do if there is no nozzle cycle?](#)

[Muzzle Velocity \[FPS\] depending on Pressure \[PSI\]](#)

- [Technical Specifications](#)

- [Legal Notice](#)

[Exclusion of Liability](#)

[Disclaimer](#)

[Intellectual Property](#)

[GATE Limited Warranty Policy](#)

[Product Disposal Instructions](#)

- [Product Compliance](#)

[Declaration of Conformity](#)

- [Stay tuned with GATE](#)

Version of Manual: 1.0.0

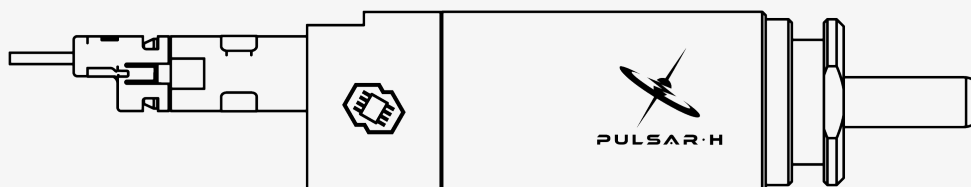

General Information

Congratulations on your brand new **GATE HPA Engine**.

PULSAR H Single Solenoid HPA Engine is increased precision and alignment tolerance thanks to an innovative 2-stage open-bolt hybrid system.

GATE technology finally breaks into the world of HPA. **Take your replica into the future!**

 The information contained in this document is subject to change without notice.

 Read carefully before use. Keep for future reference.

 Failing to read this information may void the guarantee!

 When using the product, always follow basic safety rules to reduce the risk of injury from fire or electrical shock.

Device Structure

1. Nozzle
2. Engine Front
3. Engine Body
4. Solenoid Valve
5. Air Hose
6. O-Rings:
 - 7x1 mm o-ring x 2
 - 8x1 mm o-ring x 2
 - 20x1 mm o-ring

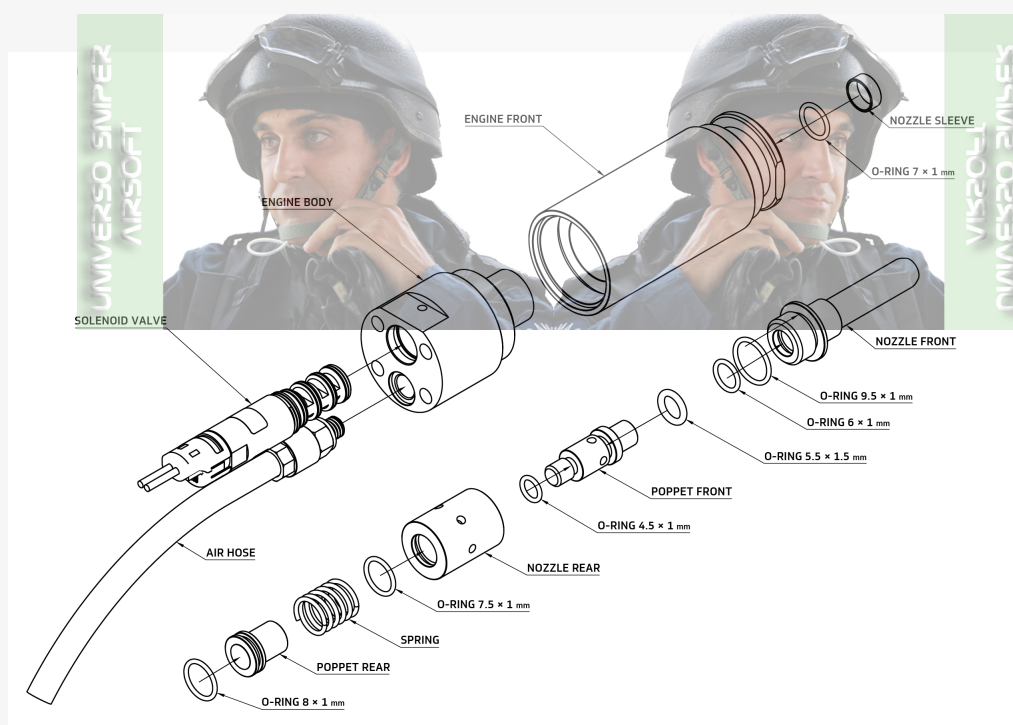

Safety Summary

Please read this to ensure safe and correct use. Retain for future reference. The information contained in this document is subject to update without notice. When using a product listed here be sure to obtain the latest specifications.

For your safety, we recommend this product to be installed by a skilled person.

 **Warning**
Situations that may cause injury to yourself or others.

 **Caution**
Situations that may cause damage to your device or other equipment.

**Note**

Notes, usage tips or additional information.

 **Warning**

This device is not a toy and may not be operated by people (including children) with limited physical or mental abilities, as well as by people with no earlier experience in operation of electronic equipment. They may use the device only under the supervision of people responsible for their safety.

 **Warning**

Before starting the installation process, make sure that your ASG replica magazine is empty and there are no BBs inside.

 **Warning**

When installing the device, every person within the replica's range must wear personal protective equipment.

 **Warning**

This equipment is not suitable for use in locations where children are likely to be present.

 **Warning**

Persons under 18 years of age ought not stay unattended near the device during the installation or servicing of a device installed in an ASG replica.

 **Warning**

Persons under 18 years of age ought not stay unattended near the device installed in an ASG replica ready for use.

 **Warning**

Persons under 18 years of age are not allowed to install or commission the device in an ASG replica.

 **Warning**

Persons under 18 years of age are not allowed to service this device.

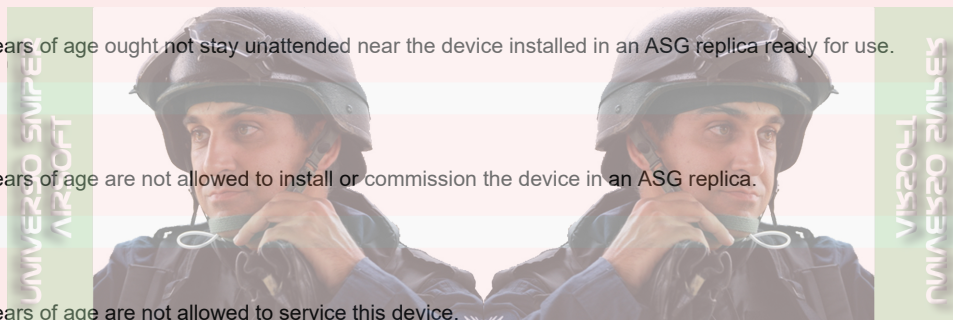
 **Warning**

Do not store or carry flammable liquids, gases or explosive materials in the same compartment as the device, its parts or accessories.

 **Warning**

Incorrectly connecting positive and negative battery terminals will cause immediate damage to the FCU, which is not covered by warranty, and can lead to fire.

 **Warning**

Applying pressure of more than 140 PSI can cause immediate damage to the device, which is not covered by the warranty, and the consequences can be very dangerous.

 **Warning**

Take caution to prevent short-circuiting the battery as the consequences may be very dangerous.

 **Warning**

Excessive trigger sensitivity may cause unintentional discharge (firing).

 **Warning**

When an airsoft replica is not in use, its battery must be disconnected and the hop-up chamber must be empty.

Warning

While handling an HPA replica with a connected battery, anyone within the range of the replica must wear personal protective equipment.

Warning

When not in SAFE mode, avoid using the device around strong electromagnetic fields, such as PMR transmitters exceeding European standards or when electrostatic discharges, e.g. lightning, occur in the atmosphere, which may cause malfunction of the device and unintentional discharge (firing).

Warning

When an airsoft gun is not in use, its magazine must be detached or kept empty with no BBs inside.

Caution

For your own safety you ought to use an additional fuse between the battery and the FCU.

Caution

When operating under unusual conditions, perform maintenance outlined below for the climate similar to your area. Operating in extremely cold temperatures is not recommended. Do not expose **PULSAR H** to direct sunlight for long periods of time. Keep away from dust or sand, which can cause malfunctions and/or excessive wear. Keep this product out of snow, rain, and water. This will prevent electrical failure and fluid buildup inside the gearbox.

Caution

Connecting batteries with nominal voltage over 7.4 V (e.g. NiMh 8.4 V, LiPo 11.1 V) can cause permanent damage to the solenoid valve or faster wear of the solenoid valve, which is not covered by warranty.

Caution

The use of CO2 may cause permanent damage to the device, which is not covered by the warranty.



Installation of PULSAR H in the Gearbox TITAN II Bluetooth®

Introductory Information

Caution

Regardless of your previous experience, follow all safety precautions to prevent any damage to your **PULSAR H**.

Caution

PULSAR H installation requires deep technical knowledge. To avoid damage, we recommend it to be installed by a skilled person. If, however, you wish to proceed with **PULSAR H** installation on your own, you must read this full-length document. Incorrect installation may result in poor performance, malfunction, damage, which are not covered by warranty.

Note

In case you have any difficulties while installing or using this product:

- contact us via <https://help.gatee.eu>
- send us an e-mail: support@gatee.eu
- join [GATE Airsoft Community Discord Server](#)

Fitting the PULSAR H Engine in the Gearbox using the example of a replica with TITAN II Bluetooth® installed

1. Have ready the replica in which you will install the PULSAR H engine.



2. Remove the gearbox shell from the replica.

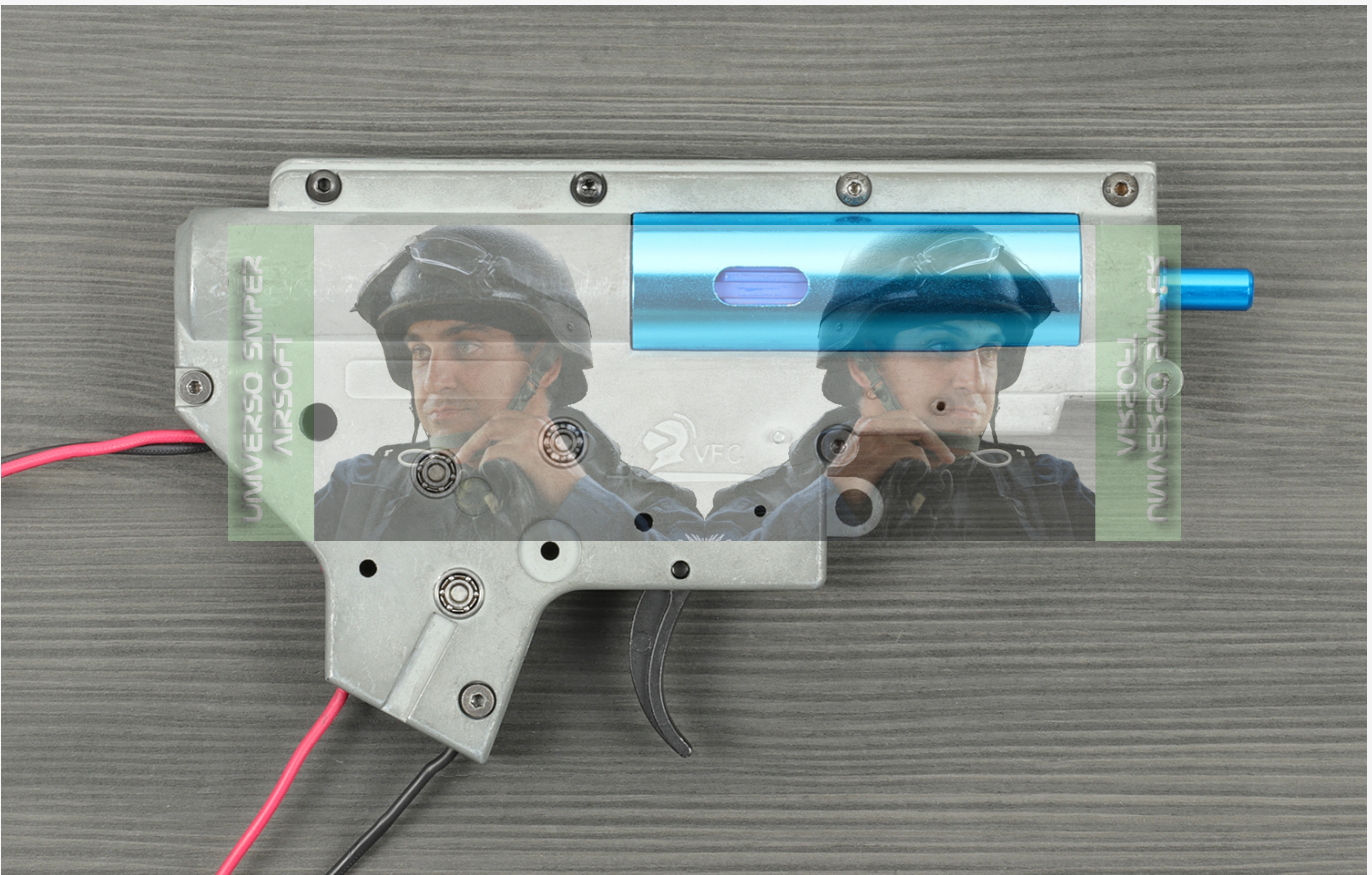

3. Remove all components from the gearbox.

4. Thoroughly clean and degrease the gearbox shell.

5. Prepare the parts that you will use again when assembling the motor:

- a. trigger together with the spring
- b. selector plate.

6. Get familiar with the contents of the PULSAR H engine packaging and the contents of the manual.



7. Prepare the items for installation:

- a. PULSAR H HPA engine
- b. Air hose
- c. TITAN II Bluetooth® V2 gearbox drop-in FCU mosfet HPA
- d. Installation kit.



8. Install the bottom PCB of TITAN II Bluetooth®. The distance around the bearing should be symmetrical.

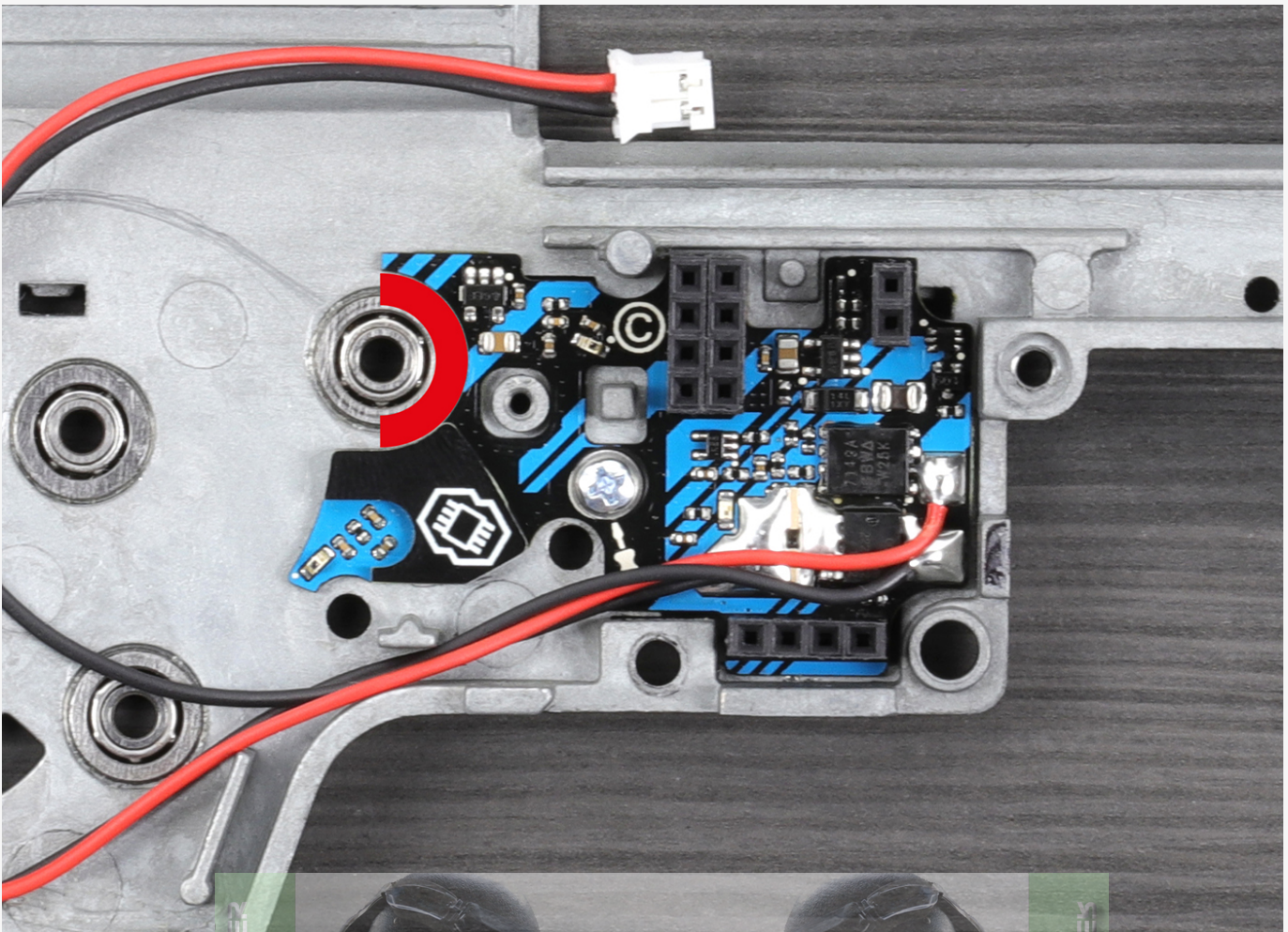

9. Place the wires as shown in the picture. Make sure that the wires do not obstruct the pin hole, the trigger sensor, and will not interfere with the trigger.

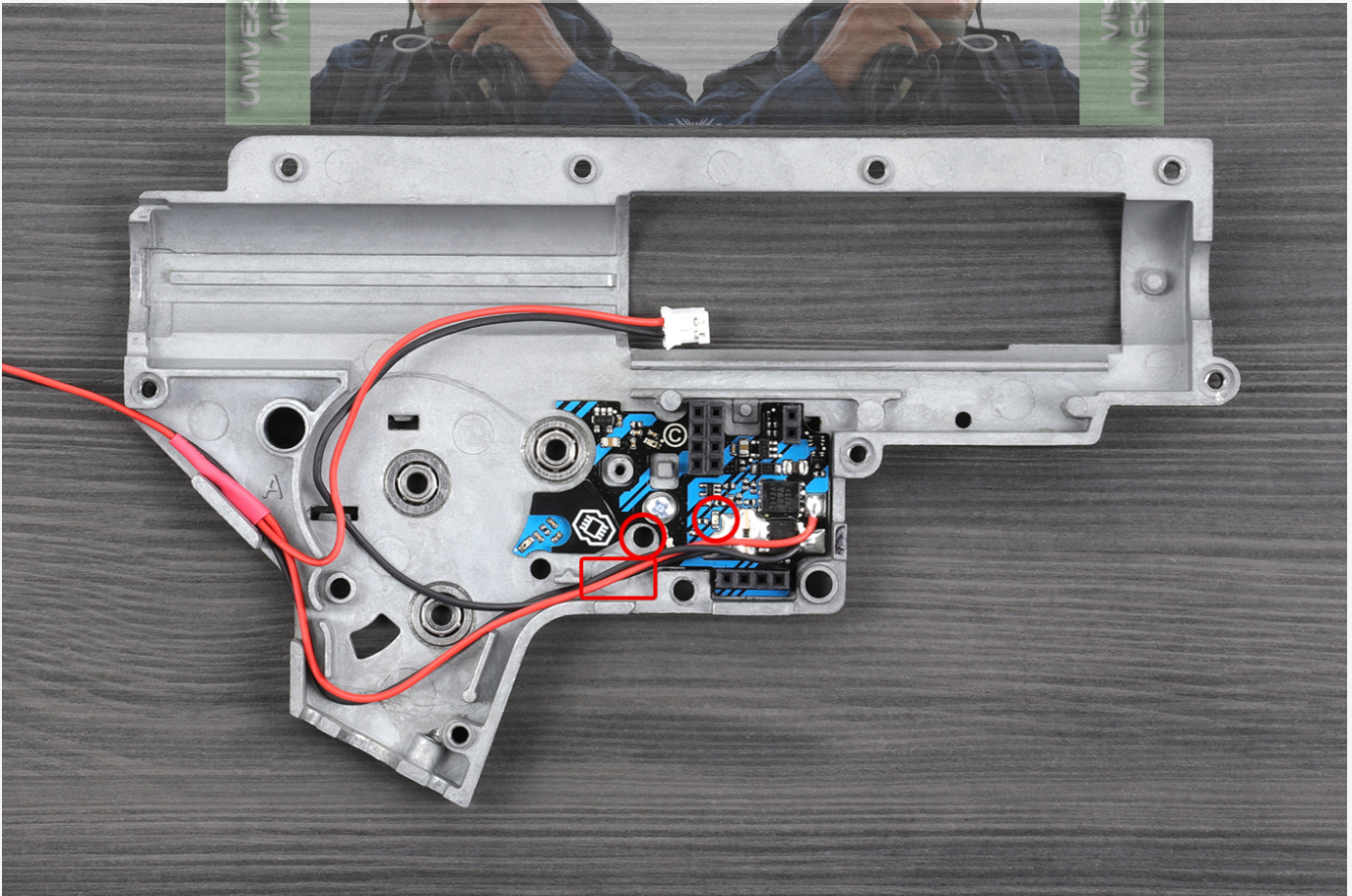

10. Screw the air hose connector into the engine opposite the valve. You can use a wrench or pliers to tighten it a little more.



11. Connect the power supply to the valve.

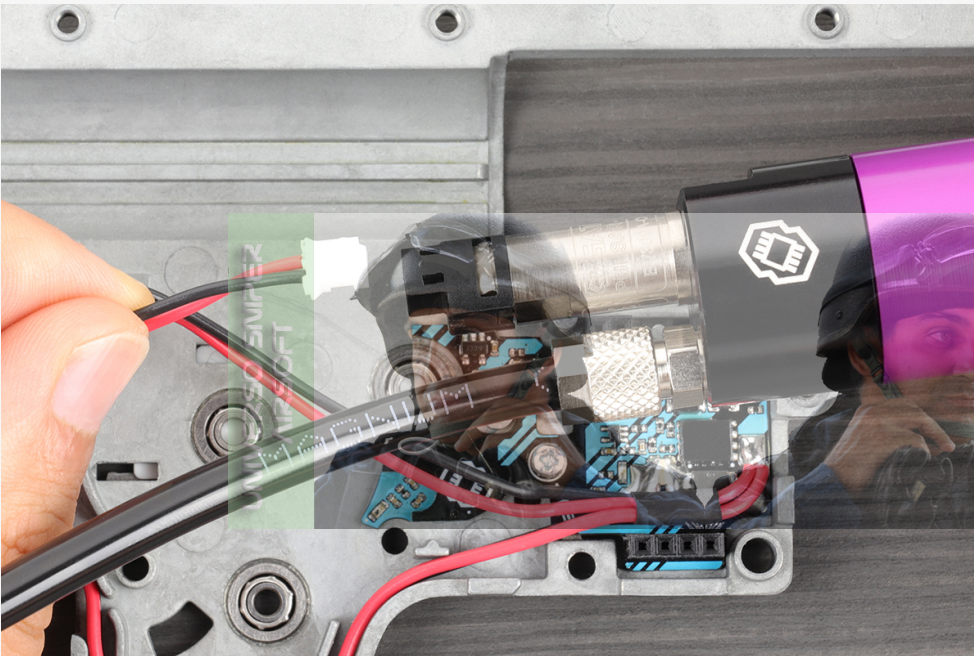

12. In the case of the ASTER II, plug the motor connectors into the cable with the connector for the single-valve HPA engine (polarity does not matter in this case) and then connect it to the valve. Here you will find the full instructions for the ASTER II Bluetooth®: <https://help.gatee.eu/space/GHC/3145891841/User+Manual+%25E2%2580%2593+ASTER+II+Bluetooth%25C2%25AE+EXPERT+for+V2+GB+%255BAEG+%2526+HPA%255D>

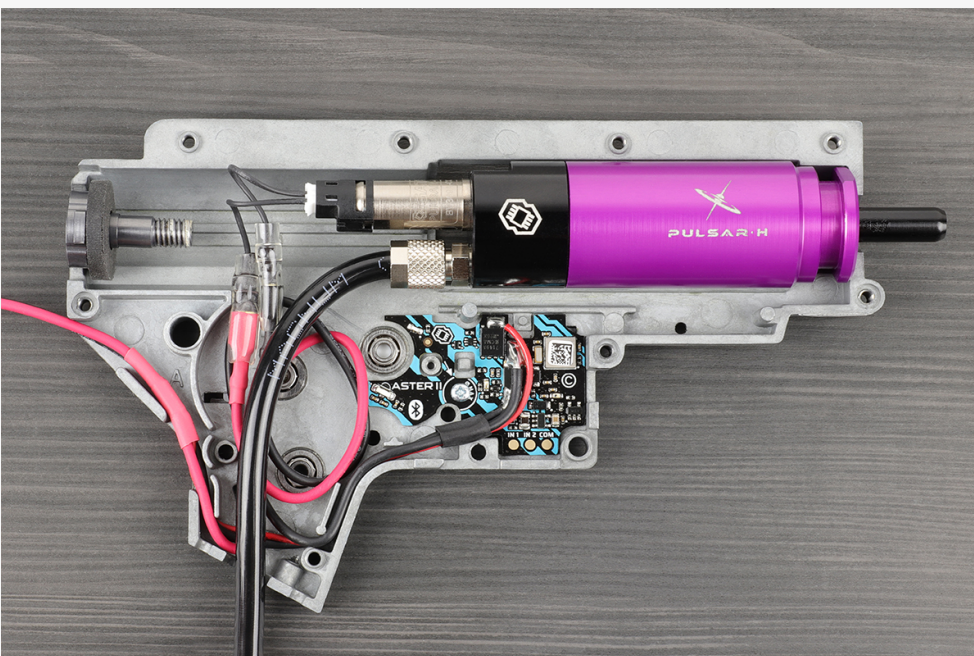

13. Place the engine in the place of the cylinder so that it is pushed against the front wall of the gearbox.

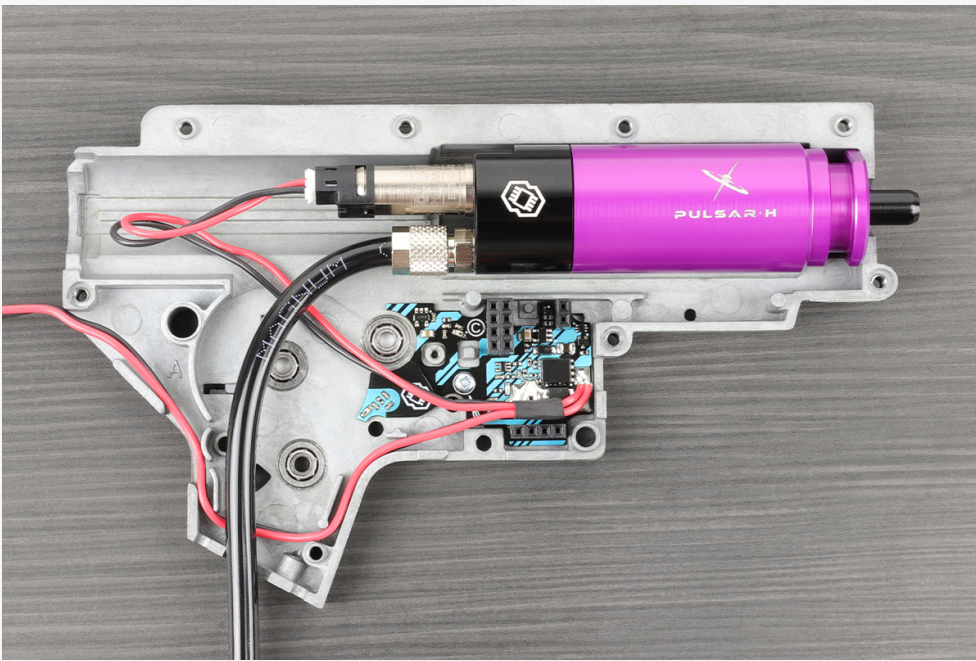

14. Install the trigger and the top PCB of TITAN II Bluetooth®. You will find the full TITAN II Bluetooth® manual here:
<https://help.gateee.eu/space/GHC/2873360445/User+Manual+%25E2%2580%2593+TITAN+II+Bluetooth%25C2%25AE+EXPERT+for+V2+GB+%255BHPA%255D>

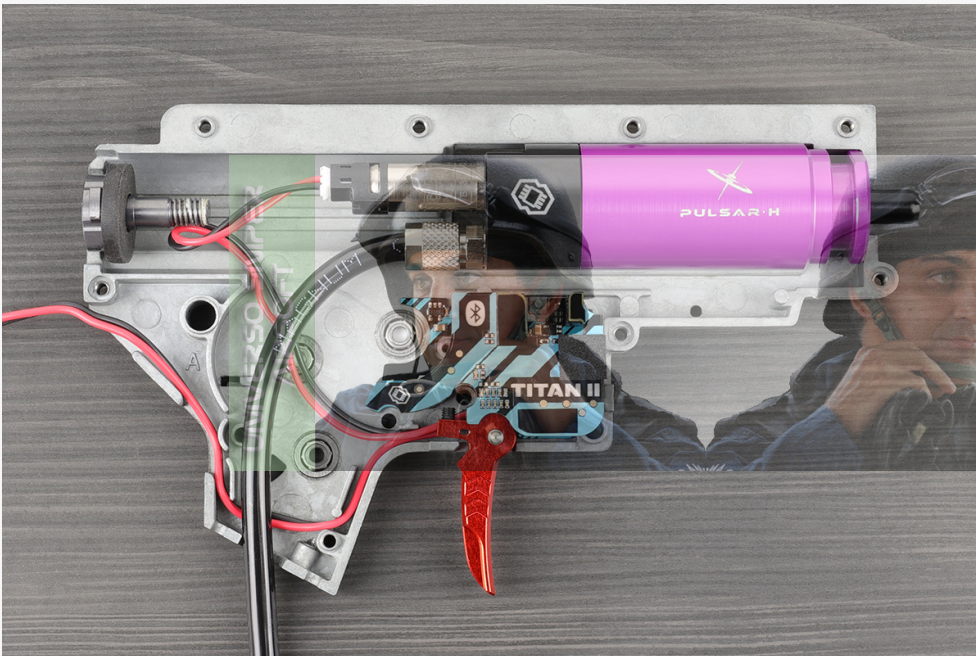

⚠ If you have a stock guide that screws into the spring guide, you will need to unscrew or shorten the spring guide so that it fits behind the engine. To stabilize the guide, we suggest using, for example, a bumper from an AEG cylinder head or enough electrical tape wrapped around the guide to stabilize the guide in the gearbox.

15. Close the gearbox shell and check that it closes evenly (do not tighten the screws). A slight gap before you have tightened it is acceptable.

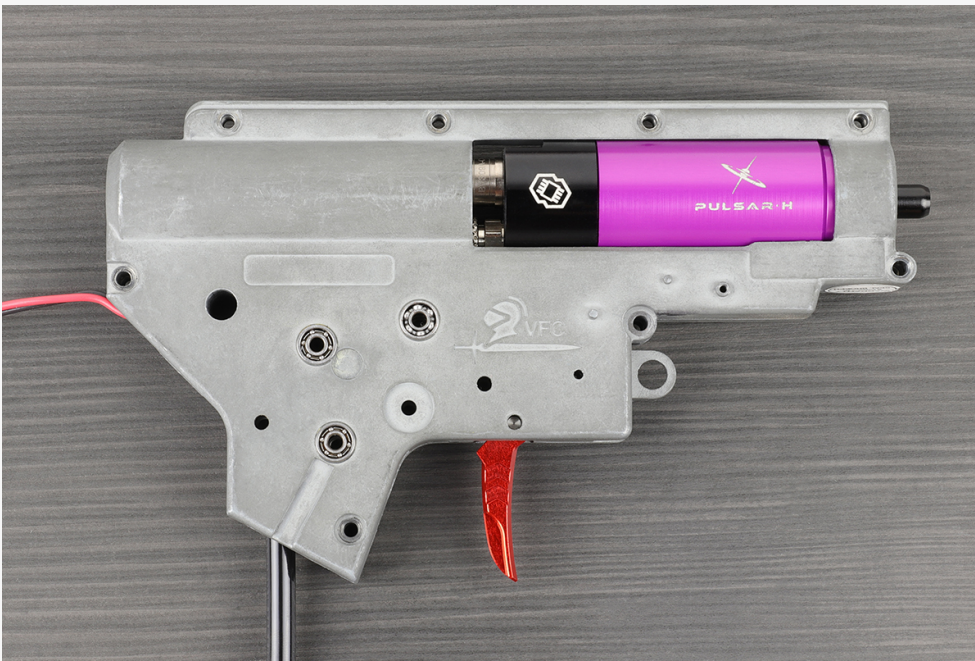

16. If everything is in order (pay attention to the wires so as not to pinch them), secure the gearbox with the screws

17. If you have an adjustable trigger, such as the Nova Trigger, you can now adjust its range of movement. This should be done before calibrating the trigger sensor.



18. Have the selector plate properly prepared by sticking the sticker from the installation kit labeled **Selector Plate Sticker** on it. Precision and accurate placement of the sticker on the plate is very important - see photo below:

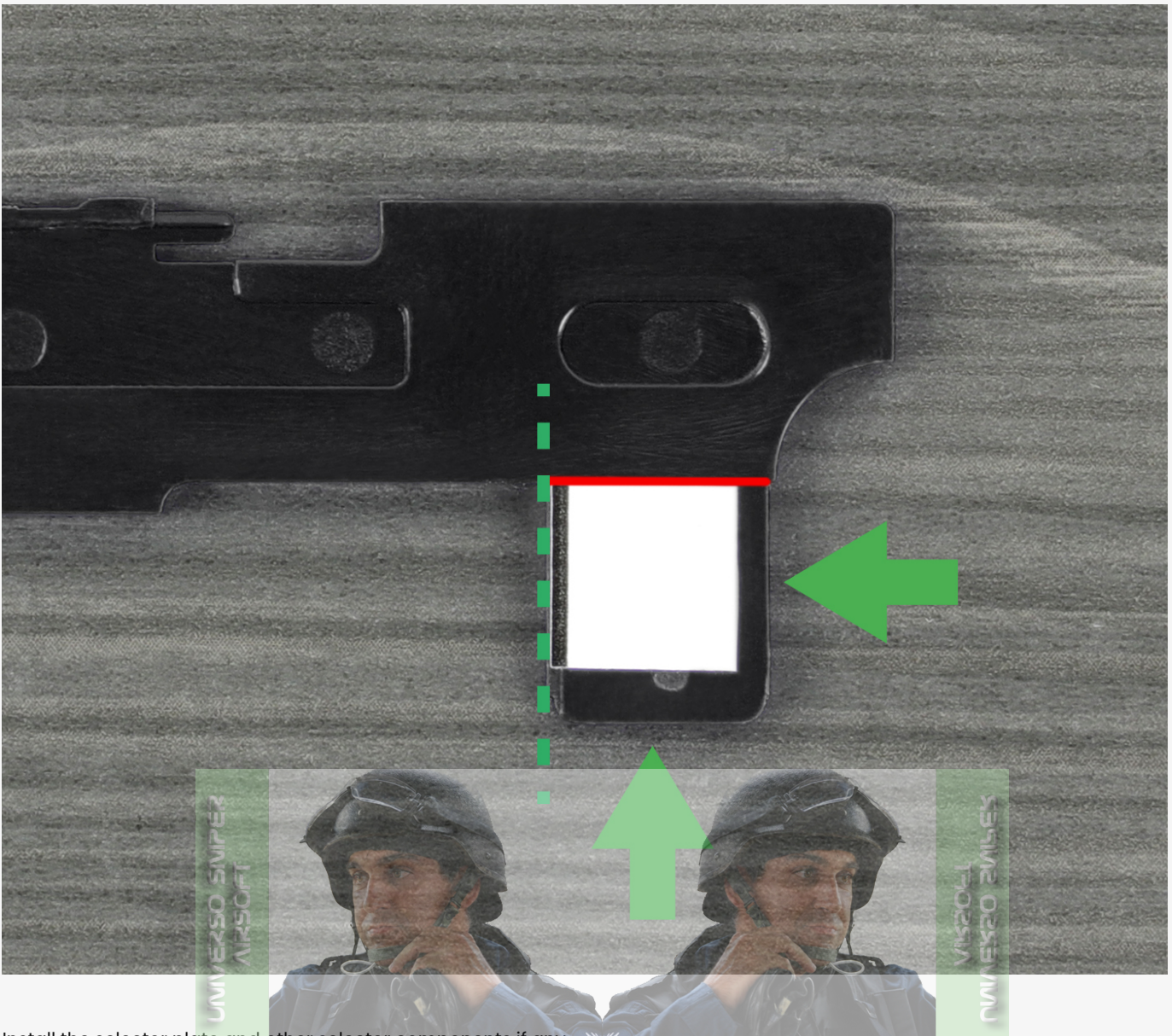

19. Install the selector plate and other selector components if any.
20. Place the shell in the body of the replica.
21. Install the grip by previously putting the air hose through the hole where the motor gear was previously located.



22. Remove the adjustment screw from the motor cover.



23. Then put the air hose through the hole where the screw was and install the cover.



24. Installing the buffer tube guide

- a. Gently tighten the guide screw so that the spring guide stays in place.
- b. Tighten the screw of the buffer tube guide until you feel resistance.

25. At the end of the air hose, install the connector in the standard you will be using.



26. Install the upper part of the replica body including the barrel and chamber.

27. Connect the battery and perform trigger and selector calibration using the GCS app.



28. Insert your magazine loaded with the BBs of the weight you're going to be using.

29. Carry out FPS measurements using a chronograph.

a. If the results are stable, proceed with accuracy test - step 30.

b. If you have encountered FPS spikes or results that are too low, then probably the gearbox has not been installed axially in the lower receiver. Go to point 31.

30. Aim test - if the previous FPS measurements and now the accuracy test are satisfactory, then your replica is ready. If you have encountered problems at any of the previous stages, proceed to the next point.

Axial alignment

31. Axial alignment is very important when building an HPA replica. HPA engines, especially those operating in an open bolt system, are very sensitive to deviations from alignment.



a. If you have specialized knowledge of replica building, you can correct the gearbox deviation from the body axis yourself. Otherwise, it is best to have a reliable service technician align the replica.



b. Using an inspection camera with a diameter of less than 6 mm is most effective in assessing the deviation from the axis.



i. Insert the camera through the barrel and bring it close to the hop-up bucking.

ii. You should then see an image similar to one of the four situations.

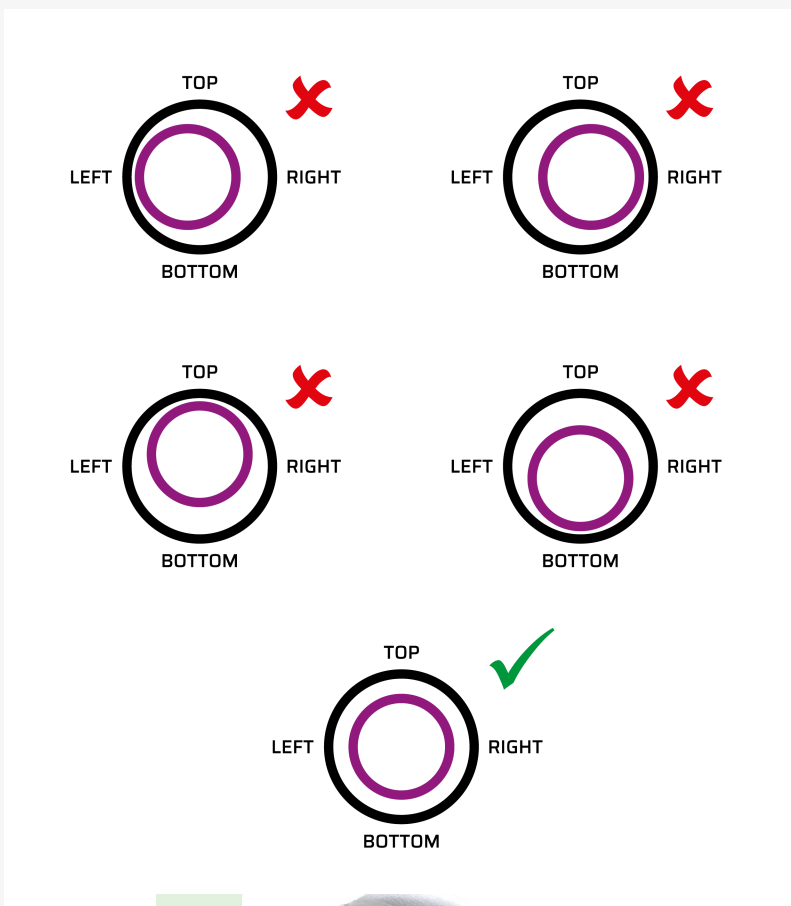

iii. The deviations shown above will result in a sudden change in the trajectory of the BB in the same direction as the deviation from the axis.

- Example: The BBs are drifted to the left – the nozzle is moved more to the left. Solution – you need to move the front of the gearbox to the right, aiming at the centric location of the nozzle in relation to the hop-up bucking. Alignment additionally should be checked with the nozzle in the front position (about 1 mm from the collar of the hop-up bucking).

When checking the alignment in the front position of the nozzle, you should also check the effect of a fully loaded magazine inserted on the alignment of the nozzle and the hop-up chamber (in some replicas, the pressure of the magazine and the BBs can cause the hop-up chamber to misalign in respect to the nozzle).

iv. Right-left correction will be carried out with the help of the adjustment screws supplied with our gearbox, which should be screwed into these holes marked in the photo and with them change the position of the gearbox. You can secure these screws with thread glue or a specific number of washers. For other gearboxes that do not have such screws, you need to drill holes in the front part of the gearbox on both sides of it, thread these holes, and fasten the screws in them, which should be handled similarly to the case of the gearbox. Otherwise, if this is not an option for you, you can use spacers in the form of various materials.

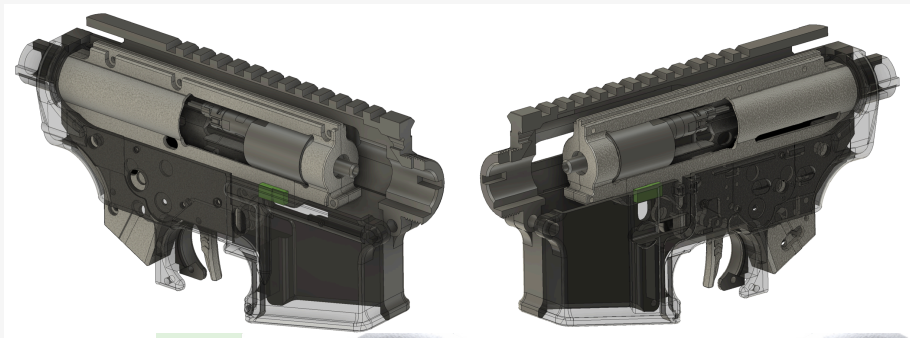

v. You will carry out the top correction by placing shimming (green color on the model) under the gearbox in the area in front of the trigger. In extreme cases, it may be necessary to get rid of the trigger pin or grind the body in the rear part where it meets the gearbox (red colored places).

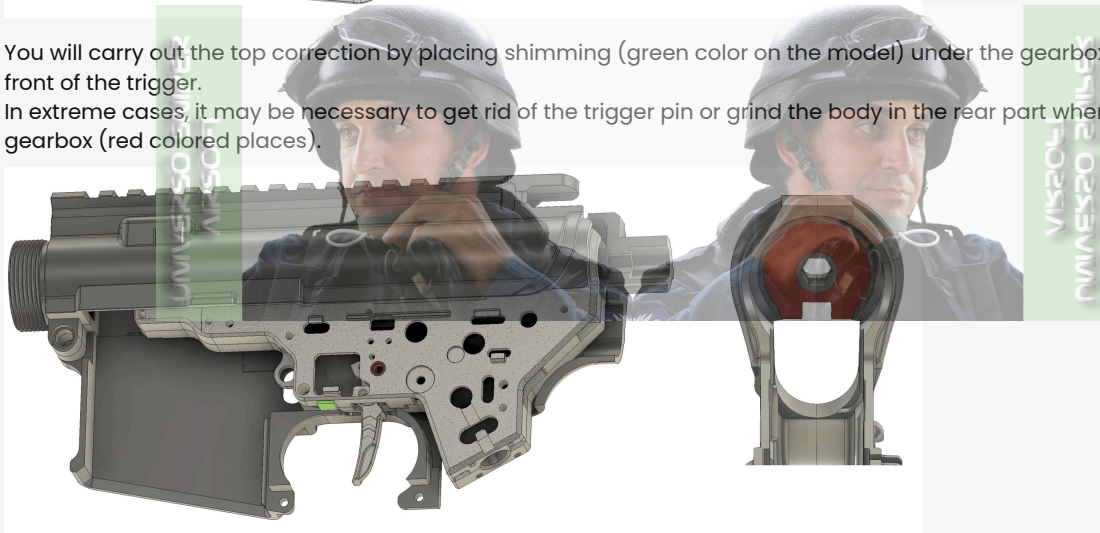

vi. You will correct the bottom correction by using shimming (green color on the model) on the back of the gearbox. In extreme cases, it may be necessary to abandon the trigger pin or grind the gearbox in the area in front of the trigger (red colored areas).



vii. In each replica, the shimming thicknesses will vary and it may require many hours of correction to achieve perfect alignment of the replica. However, this will bring very good results in the form of stable FPS measurements and a repeatable BB trajectory, resulting in high accuracy.

- c. The correctness of the replica is also affected by the stability of the gearbox seating in the body. To check the replica in this regard, observe what happens to the nozzle (observing it through the barrel) when trying to manipulate the pistol grip right-left and back-and-forth. If the nozzle moves during this activity, the gearbox shell will require additional restraining. For this purpose, first of all, we recommend tightening the screw holding the buffer tube to the spring guide previously inserted in the gearbox (you can achieve stable placement of the spring guide in the gearbox by wrapping a thick layer of insulating tape over it).
- d. The flange of the hop-up bucking, like the nozzle, must also be evenly aligned with the axis of the barrel. Any deformation of it or uneven alignment will directly affect the accuracy (e.g., a flange protruding from the right side, will drive the BBs to the right, a flange protruding from the top, may lead to unstable BB feed).
- e. To improve flange alignment:
- Tighten the hop-up bucking and try to install it again using silicone oil (be careful not to get oil on the surfaces in contact with the BB) and slow movement while sliding the barrel with the bucking into the hop-up chamber (you may have to do this several times).
 - If the flange gets misaligned each time, use different bucking, barrel or chamber.

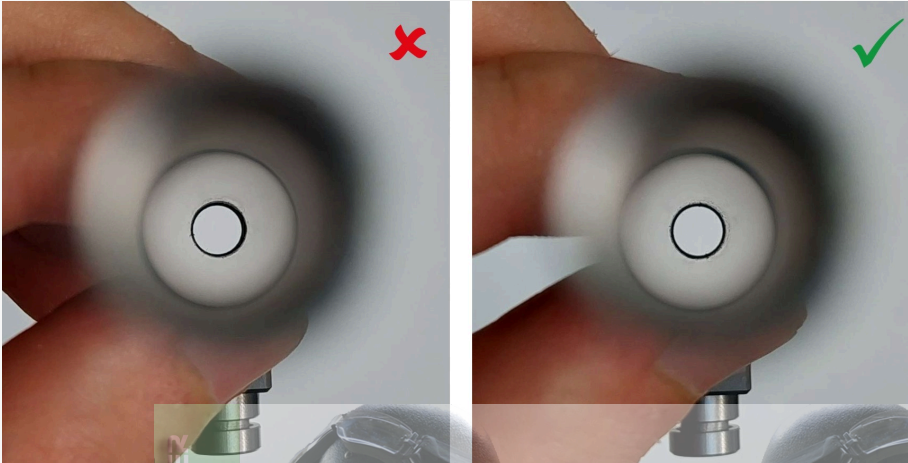

iii. If you overcome the problem and improve the axiality of your replica, it is ready for use.

[User Manual – TITAN II Bluetooth® EXPERT for V2 GB \[HPA\]](#)

[User Manual – ASTER II Bluetooth® EXPERT for V2 GB \[AEG & HPA\]](#)

[User Manual – ASTER II Bluetooth® EXPERT for V3 GB \[AEG & HPA\]](#)

PULSAR H Engine Maintenance

The PULSAR H will require periodic cleaning and maintenance. The frequency of use of the replica and possible dirtiness of the entire system will define the intervals between these procedures. Carry out preventive cleaning once every six months, if you do not notice any incorrect operation before that. If the engine does not work properly, then immediately disassemble it (carefully remove the solenoid valve - its seals are very delicate) and wash it thoroughly, for example, with petroleum ether. This does not apply to the solenoid valve - clean the solenoid valve gently with paper.

Evaluate the state of wear of the o-rings and, if they are damaged, replace them with new ones (spare o-rings can be found in the kit - this does not apply to the solenoid valve washers). Carefully remove old o-rings and install new ones. Do not use sharp metal tools for this purpose, which can damage the o-rings or aluminum surfaces of engine components. This may result in permanent damage, which is not covered by the warranty. If you have any doubts or problems, contact our technical support department. Each component is available as separate products for post-warranty support.

Necessary tools

1. PULSAR H engine

a. Optional - spare o-rings included in the kit

2. Gun Sav grease from TechT (you can use another one, but we do not guarantee perfect engine performance then)



3. Clean, fine brush for applying the grease

4. Plastic tweezers for removing and installing the o-rings

5. A clean thicker brush for washing the parts

6. A degreasing agent for all components, such as petroleum ether (the agent must not damage the o-rings)

7. A container for washing the components

8. Paper towels

Maintenance manual



1. Have all the listed items ready.



2. Remove the air hose.



3. Unscrew the front of the engine.



4. Remove the nozzle from the engine body.



5. Gently unscrew the valve (be careful of the very delicate O-rings on the valve).



6. Remove all the o-rings from the engine components except the valve (it is best to use plastic tools for this so as not to damage the aluminum surfaces of the engine - this is not covered by the warranty).

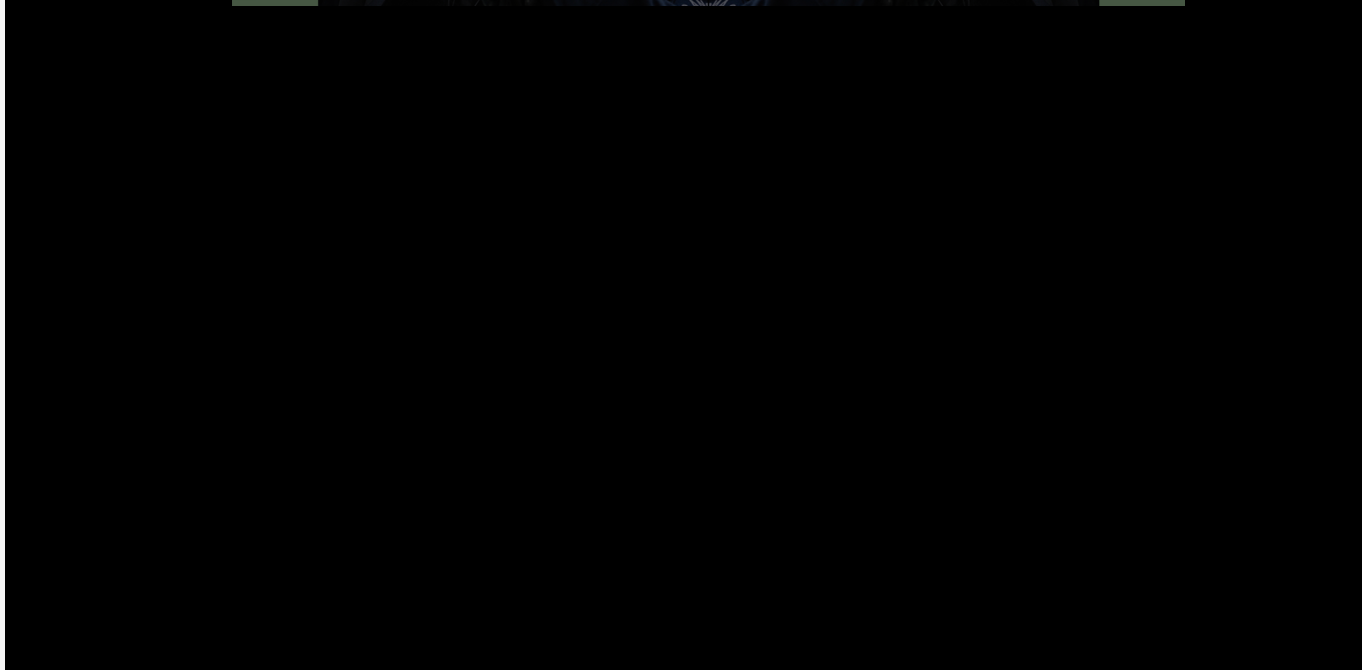

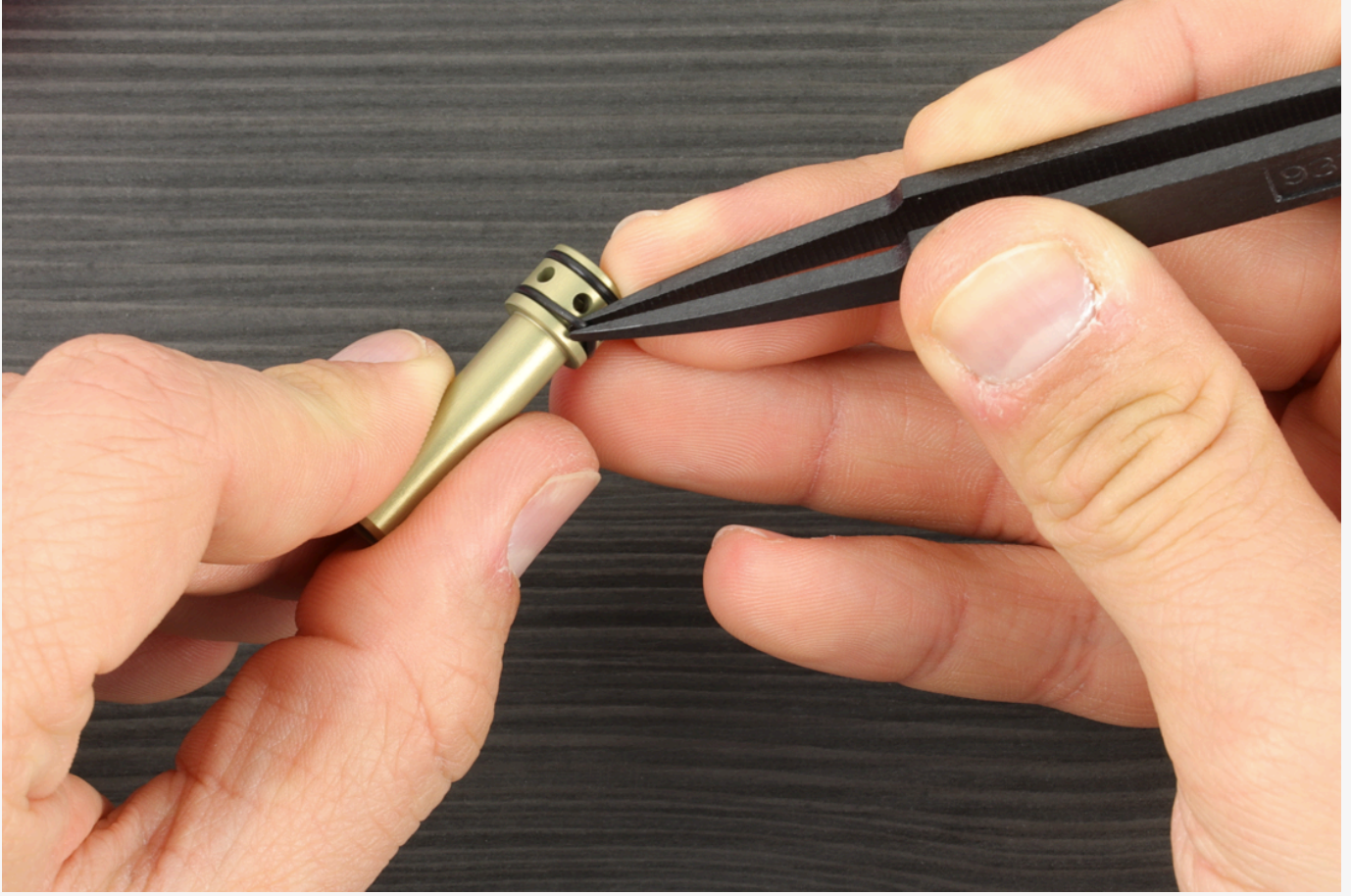

a. If the o-rings are not damaged, you can reuse them after cleaning them with a paper towel (it is best to avoid washing the o-rings with detergents).

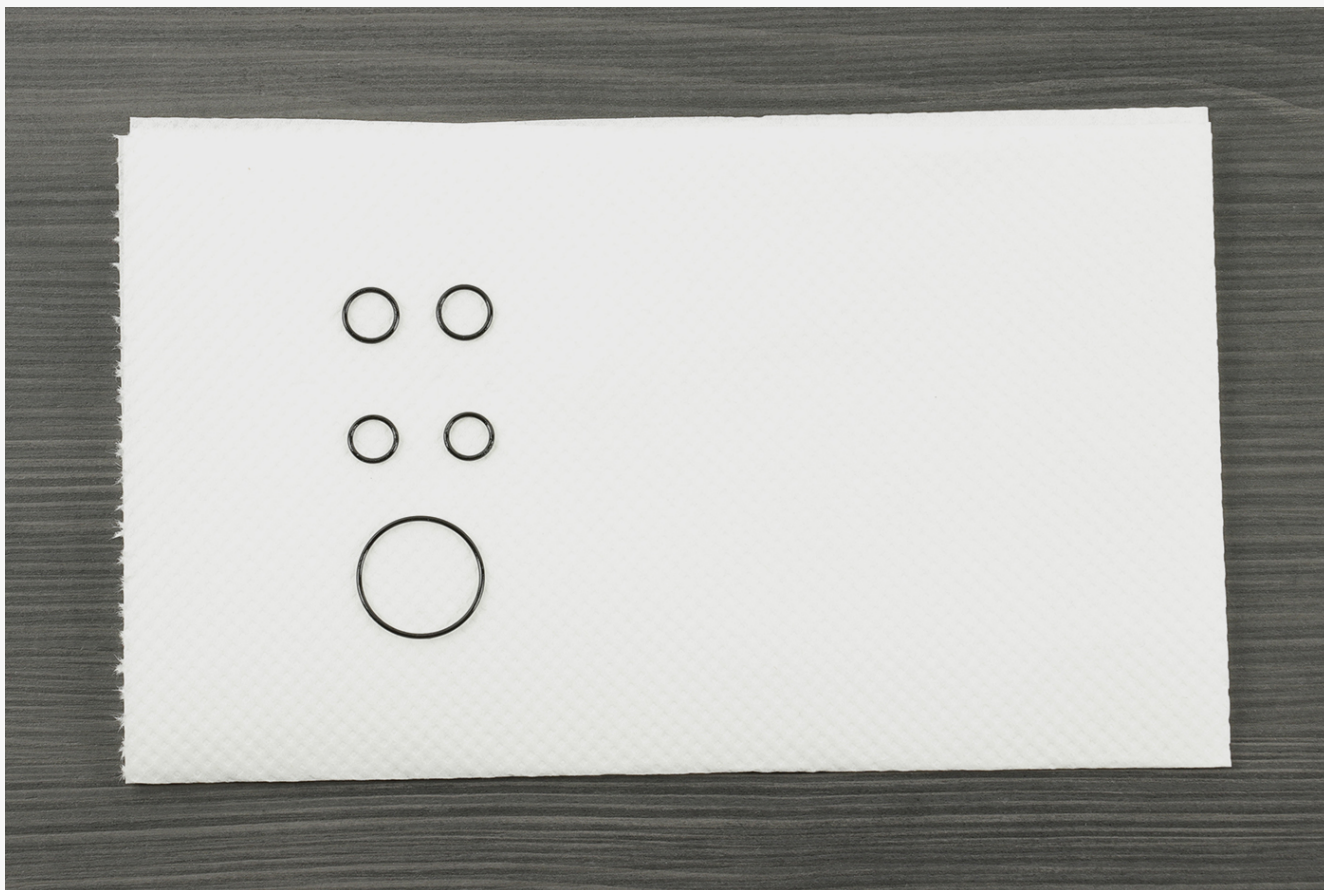

b. If the o-rings are damaged or show signs of wear, replace them with new ones - included in the kit.



7. Place the engine components in a dish with petroleum ether (NOTE - does not apply to the valve. Avoid immersing it in cleaning agents).

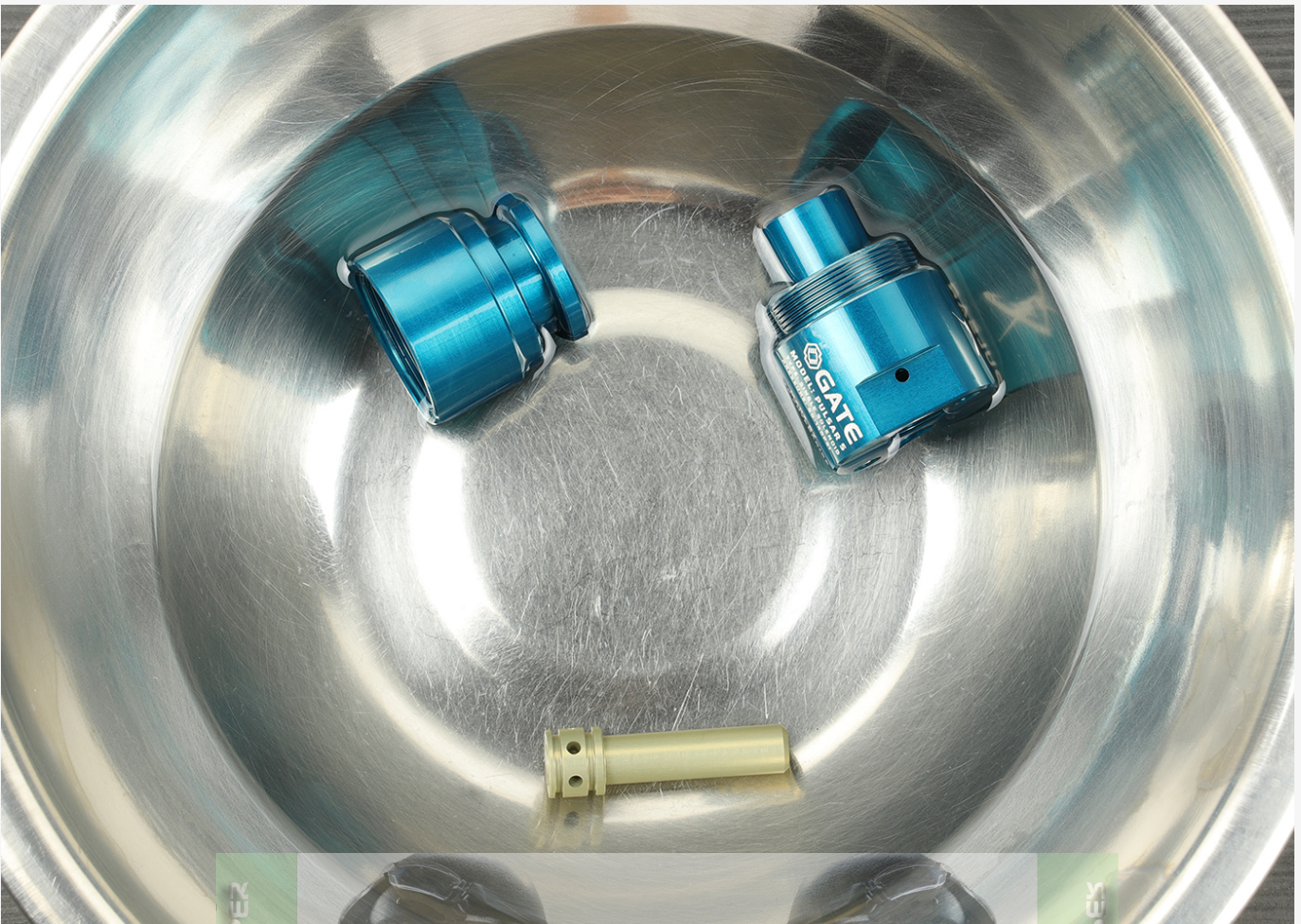

UNIVERSO SMIFER
AIRSOFT

UNIVERSO SMIFER
AIRSOFT

8. Using a thicker brush and tweezers, thoroughly clean the engine components.





9. Wipe the o-ring surfaces gently and remove visible dirt with a dry brush.



10. Set the washed parts aside on a paper towel to dry completely (you can speed up the process by blowing the parts with compressed air).

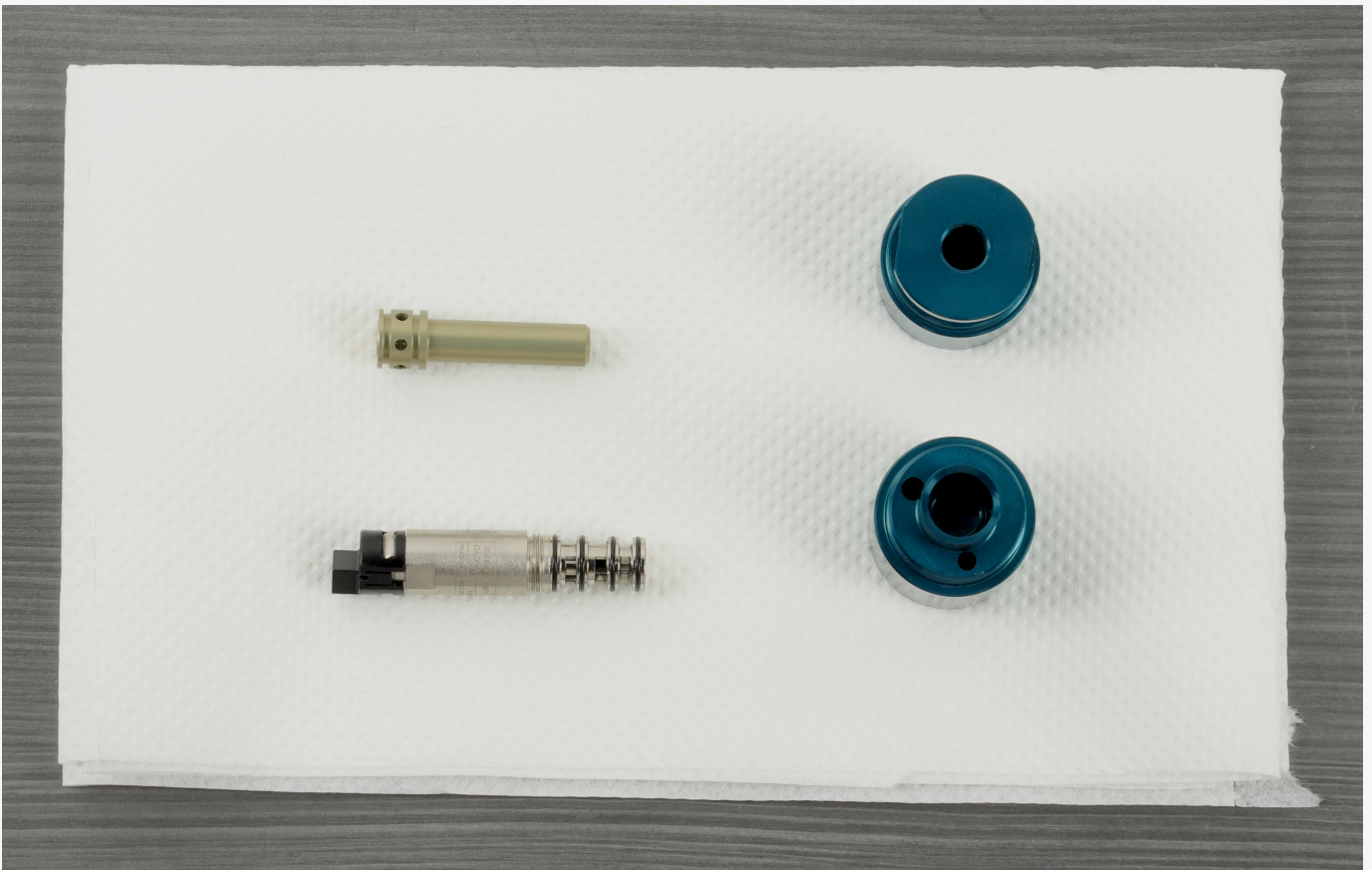

11. Prepare the kit for reassembly.

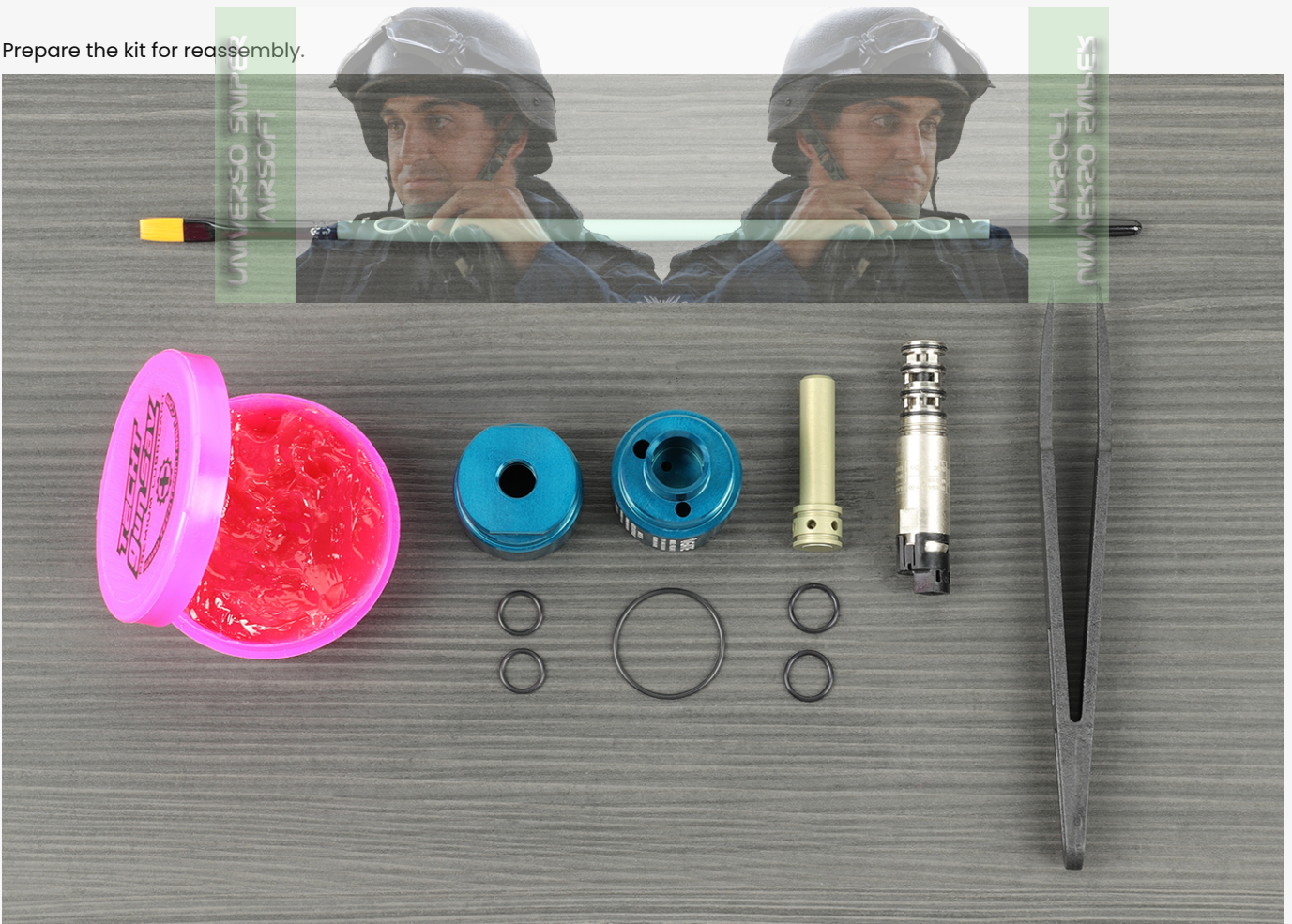

12. Reinstall the O-rings (you can gently grease them before installation):



a. 2 pieces of 7x1 mm in the front of the engine.



b. 2 pieces of 8x1 mm on the nozzle.



c. 1 piece 20x1 mm for the engine body.

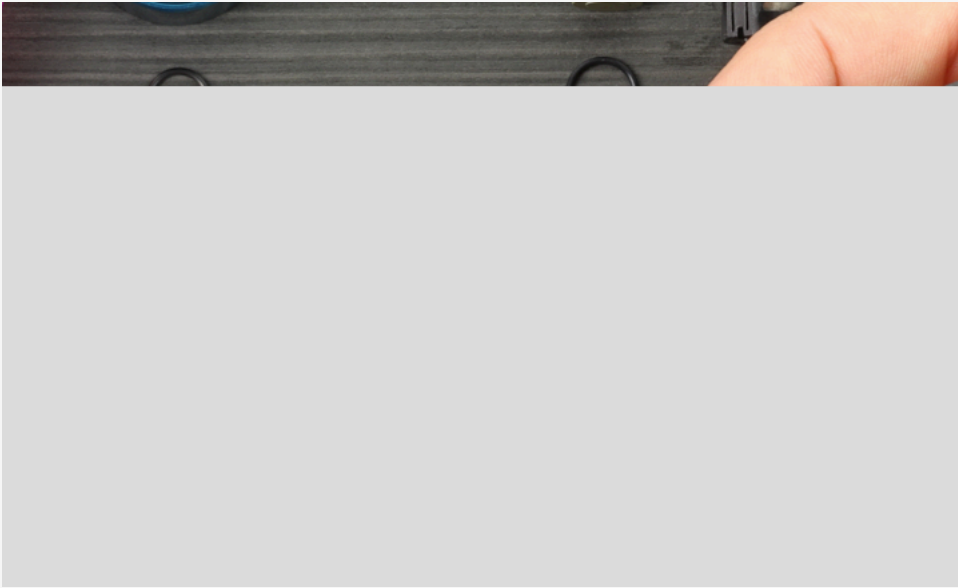

13. Prepare all parts with the o-rings installed, as well as grease and a smaller brush.



14. Grease well the two o-rings in the front of the engine (you can remove the excess with a paper towel).

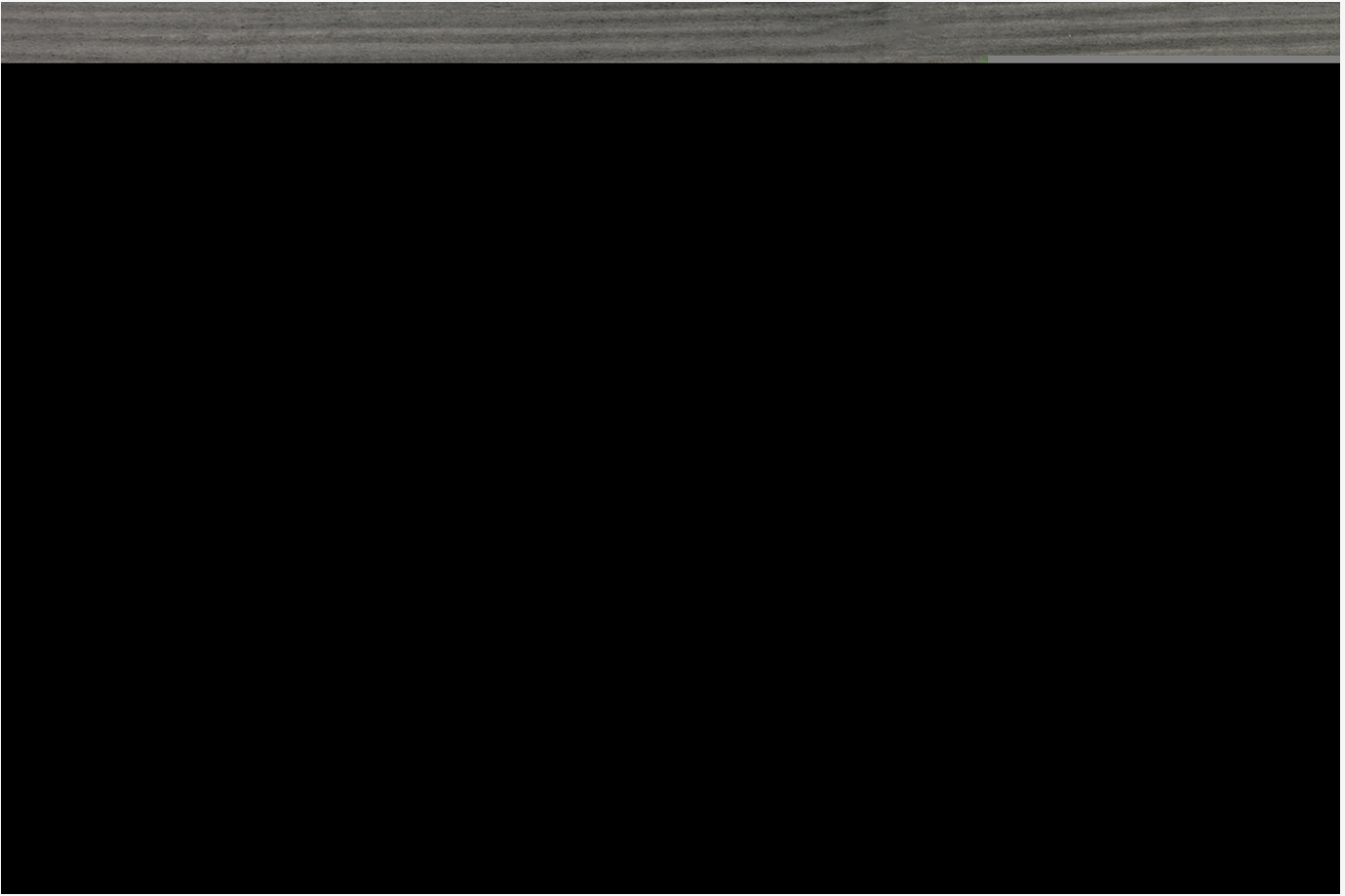

15. In the rear of the engine body, grease two places:

a. O-ring and thread.

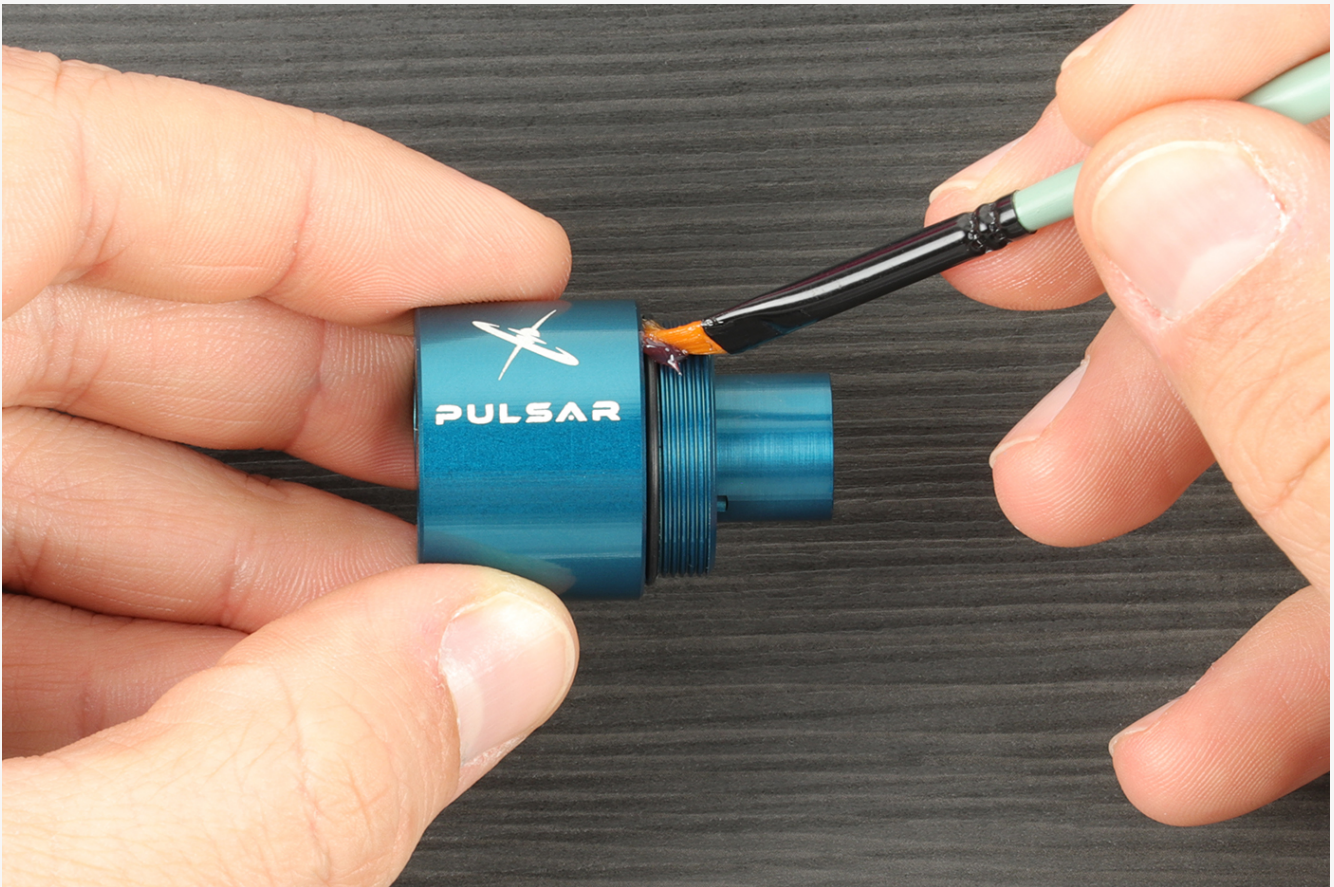

b. Then the vertical surfaces of the cylinder where the nozzle moves. Try not to lubricate the bottom of the cylinder. This can have a negative effect on the operation of the engine.



16. We also lubricate two places in the nozzle:



a. Both O-rings. As with the engine body, be careful not to leave grease on the flat rear surface of the nozzle.

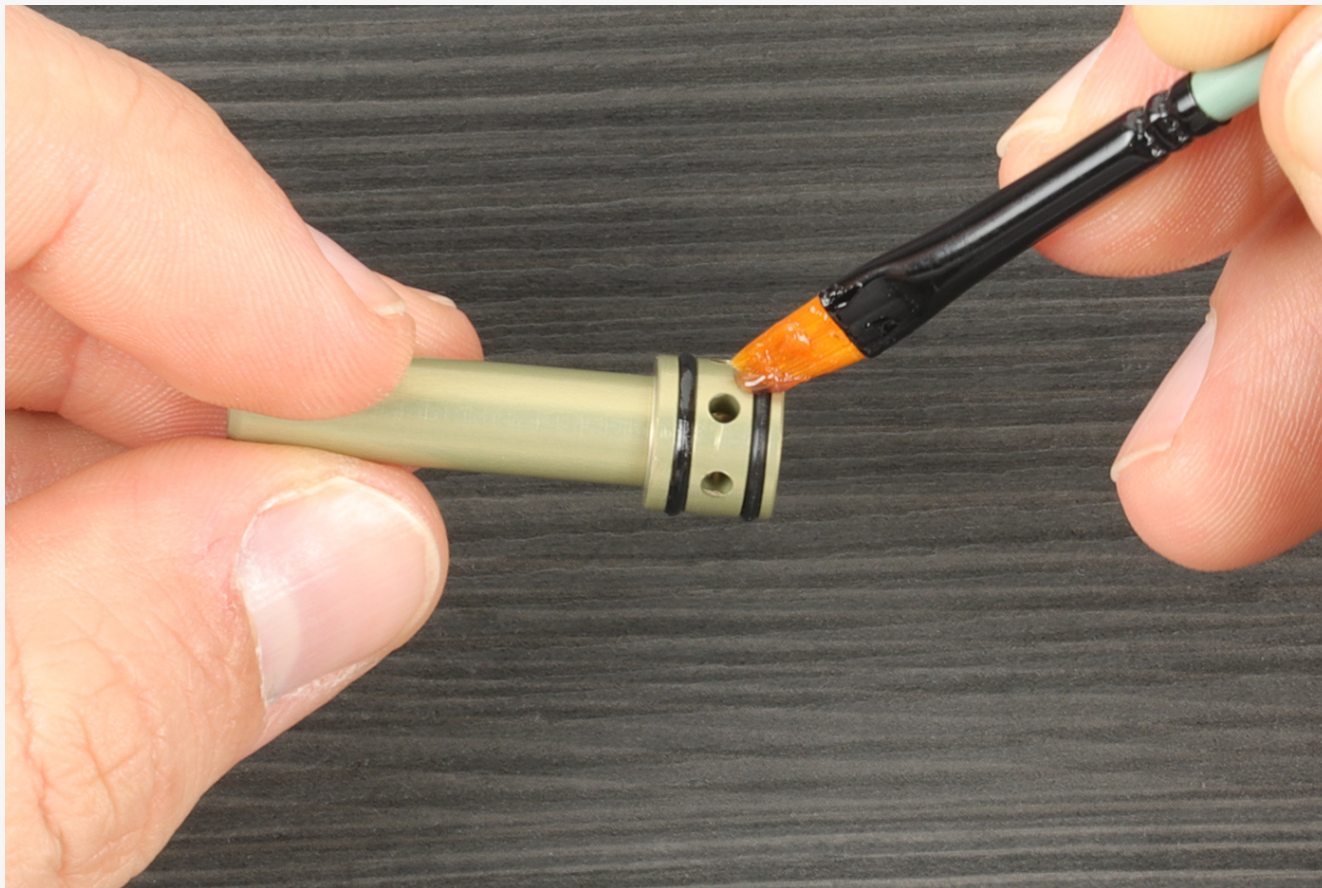

b. And the narrowed surface of the nozzle. There may be more grease here.

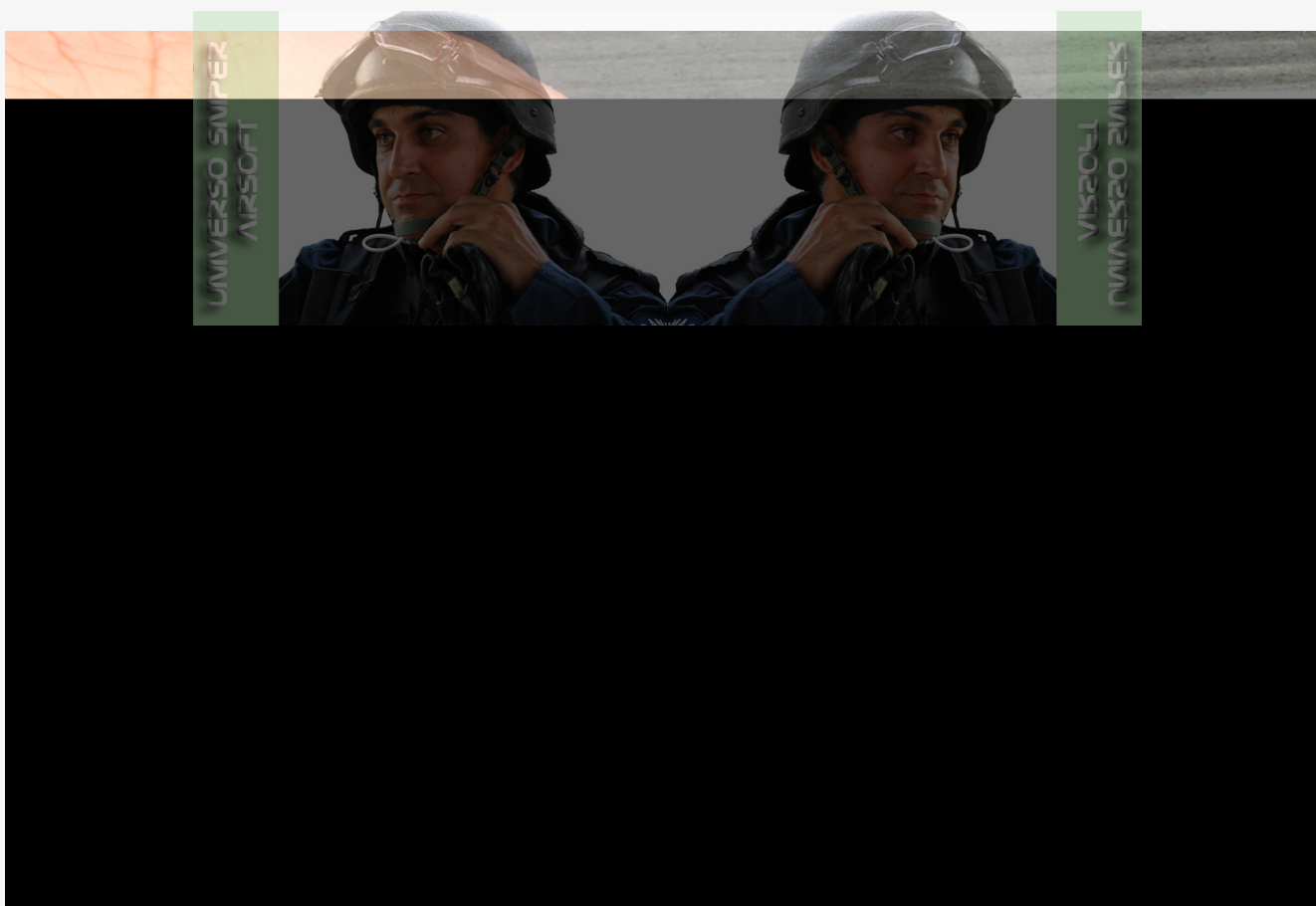

17. Place the greased nozzle in the engine body.



18. Then screw the engine front (excess grease may collect on the nozzle - remove it with a paper towel).

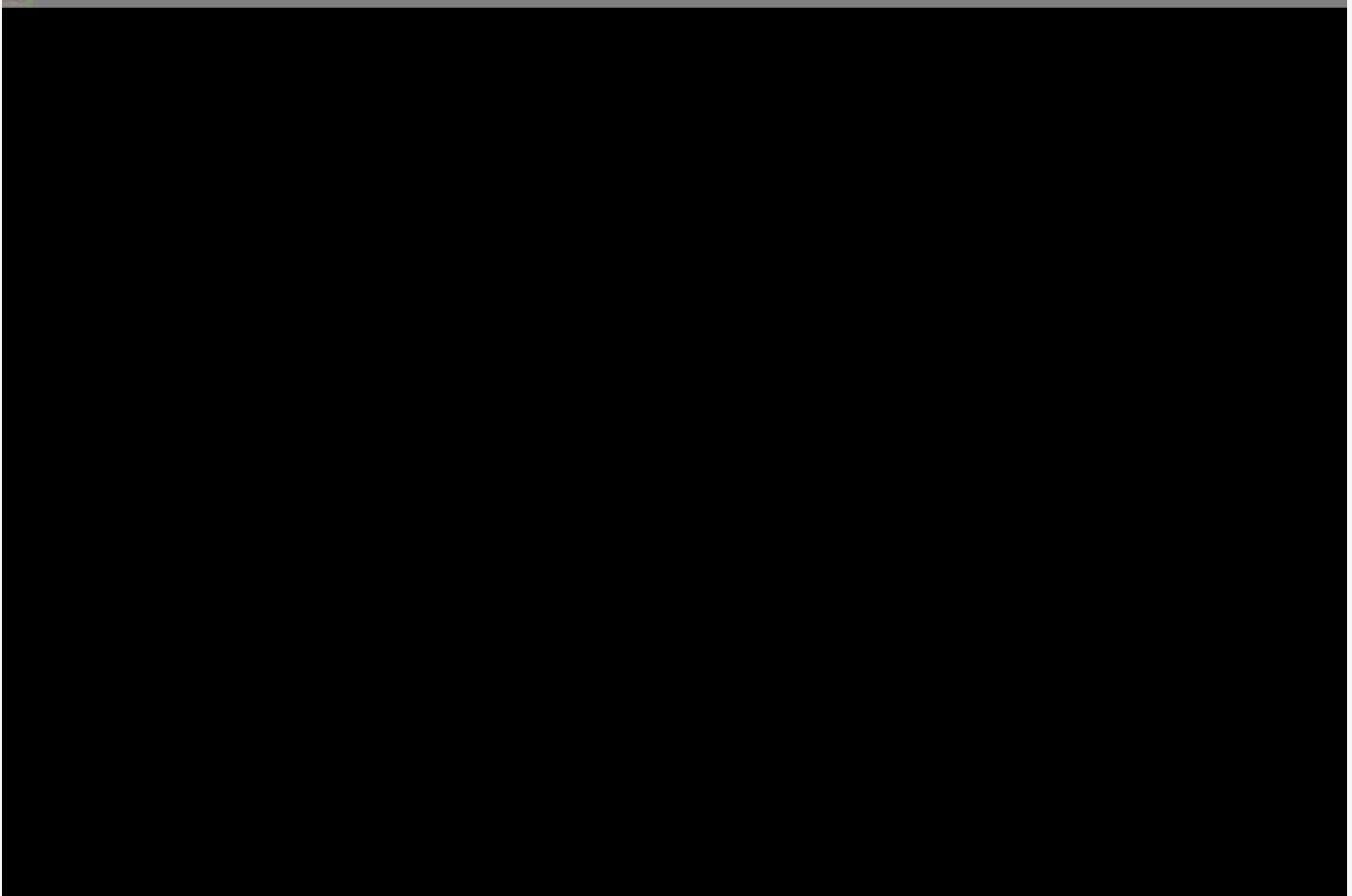

19. With the flat surface of a brush, gently grease the threads and o-rings of the valve. Avoid getting grease into the moving parts of the valve.

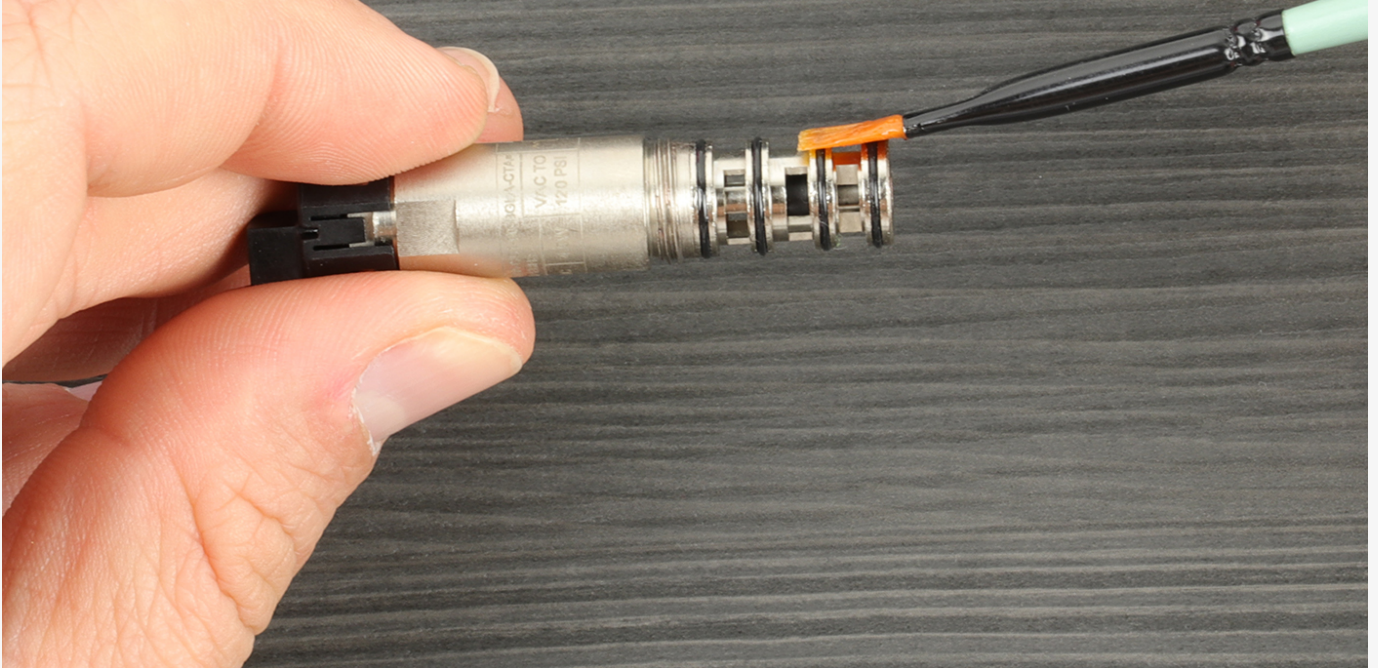
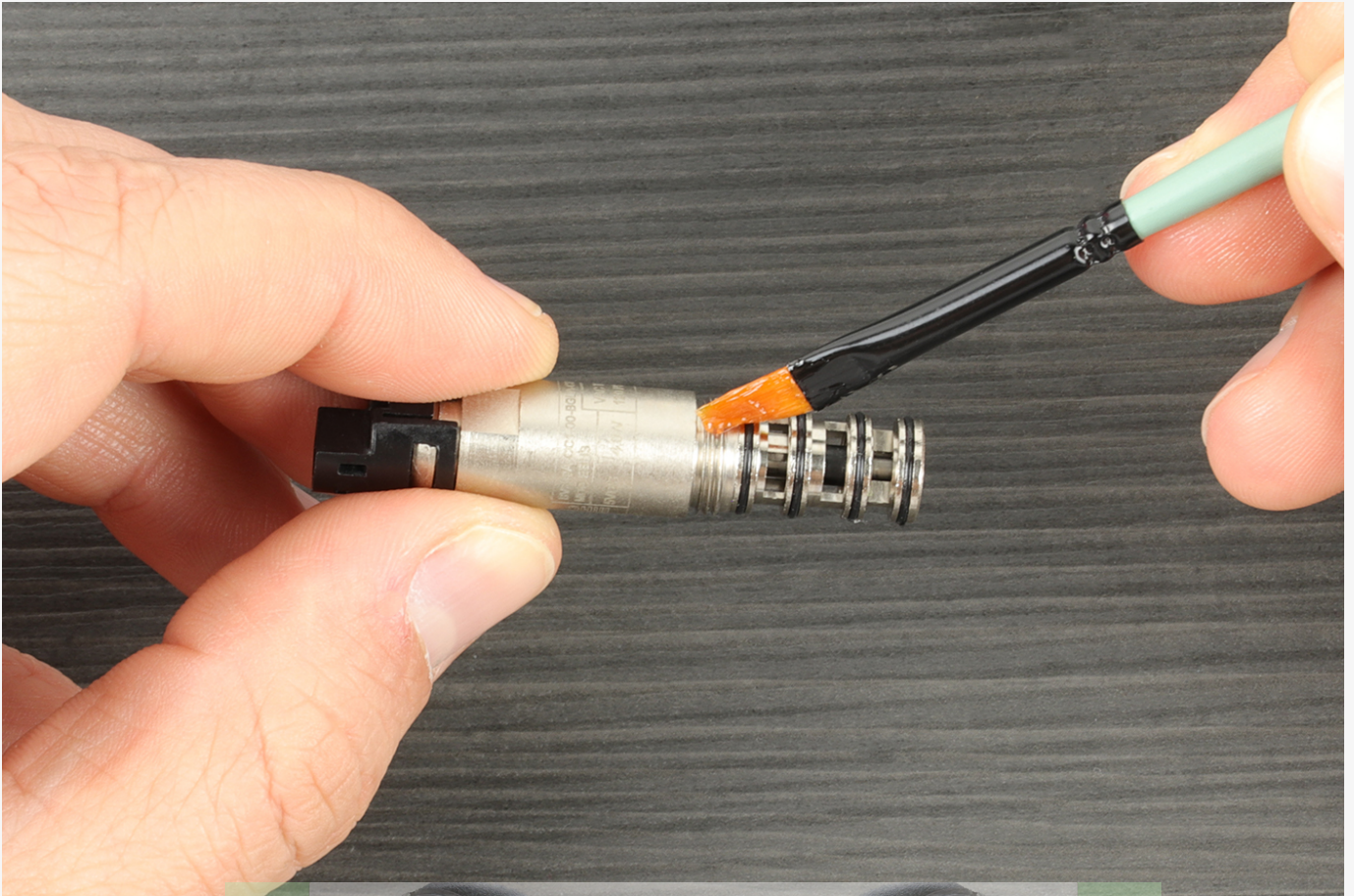

20. Gently, being careful of the valve's o-rings, screw the valve into the socket. It is enough to do this with your bare hand, do not use tools for this.



21. Screw on the air hose.



22. The engine is ready to be used again.



Repair Kit

Use the repair kit if any of the o-rings are damaged/worn.

Contents:

1 x 20 x 1 mm o-ring

2 x 8 x 1 mm o-ring

2 x 7x1 mm o-ring



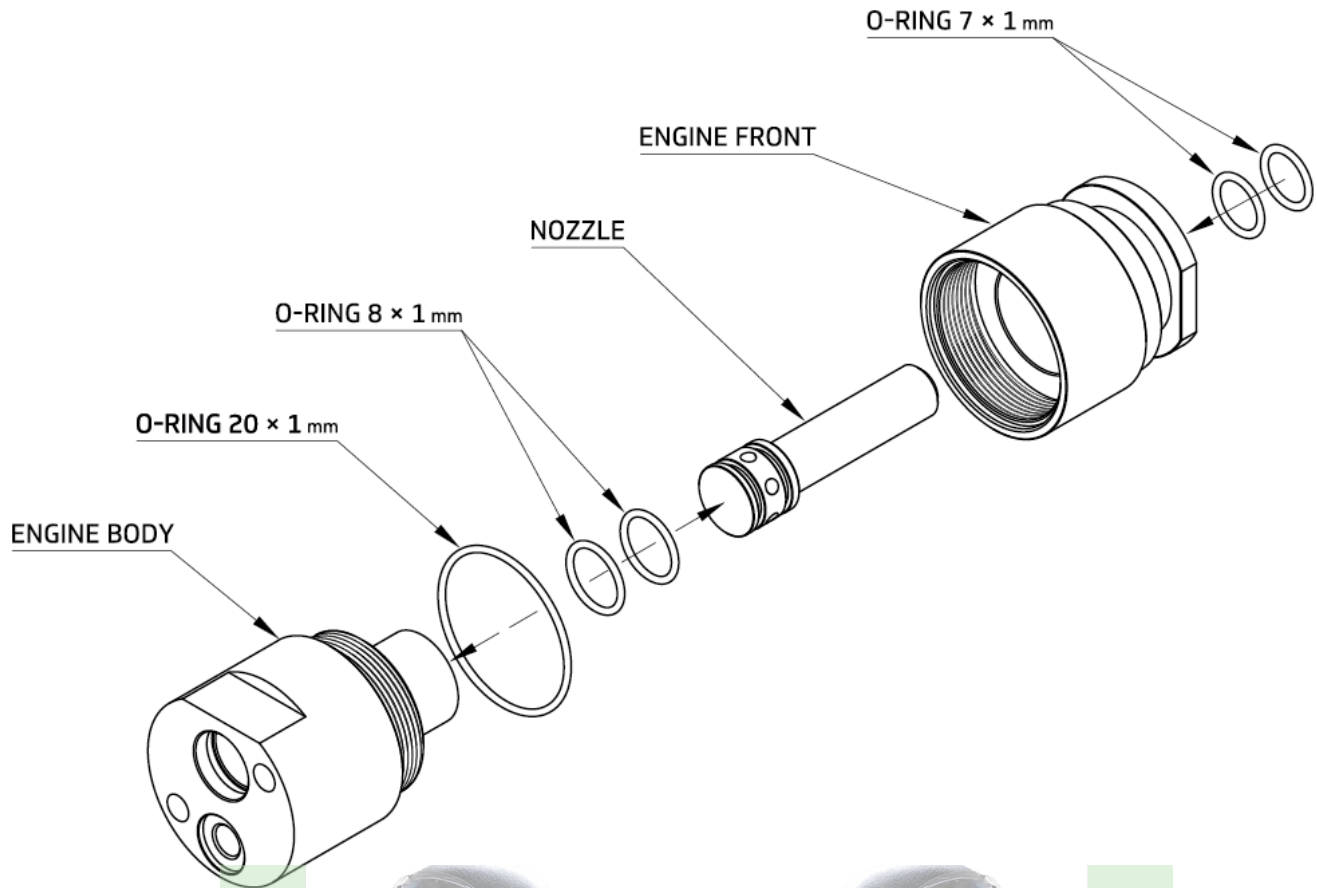

Troubleshooting

Which Hop-Up bucking should be used with the PULSAR H engine?

Everything always depends on the chamber, the power of the replica and the BBs used. In general, we recommend testing individually in your configuration, because there is no rule that any bucking will always work. From our experience, most often such as these work correctly:

- Maple Leaf Mr. Hop (rubber version)
- Madbull Blue
- TNT Black with nub
- G&G green
- LayLax PROMETHEUS Straight Chamber Hop Up Bucking Soft (Blue)
- others

We do not recommend using silicone Hop-Up buckings with PULSAR engines. Silicone buckings have lower resistance to friction and wear, causing them to wear out faster. Additionally, silicone tends to change its properties in extreme temperatures, which negatively affects the consistency of BB spin.

Which medium can I use for the power supply of the engine?

You can safely use high pressure air. Bear in mind the use of CO2 may cause permanent damage to the device, which is not covered by the warranty.

What thread for the power line?

M5 thread 0.8 mm pitch.

Are there IGL lines available for the engine?

Probably not, all engines on the market have inch threads. Our line is robust enough due to the fact that a bolt-on threaded end has been used in it, and there is no need to replace it with IGL, as with other engines.

Is the PULSAR H engine close or open bolt?

The PULSAR H is a single solenoid valve engine and operates on an open-bolt system.

How much maximum pressure can I set with the PULSAR H engine

The engine is designed to operate with a maximum pressure of 140 PSI.

I have a problem with low FPS

The first thing to check is:

- the hop-up bucking
- the hop-up chamber
- the HPA engine settings in the GCS application





HPA Engine



Main Valve Time (dP) 15.0 ms

Main Valve Pause 15.0 ms

Advanced Settings



RPS

33

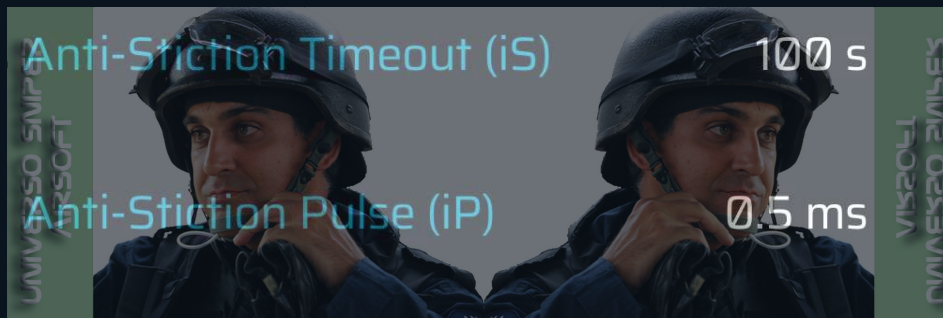

HPA Calibration Manual

Engine

TITAN II supports different types of engines - here you can choose what type of engine you have so that the program controls it correctly

Operation Mode (OB/CB)

Dual Solenoid Valve Engine mode - here you can select the mode of operation of the dual solenoid valve engine:



What regulators are compatible with the PULSAR H?

PolarStar MRS

Redline SFR

Wolverine STORM

What to do if there is no nozzle cycle?

Take the engine apart and check for excess grease - on the flat surface of the nozzle and the bottom of the cylinder in which it moves.

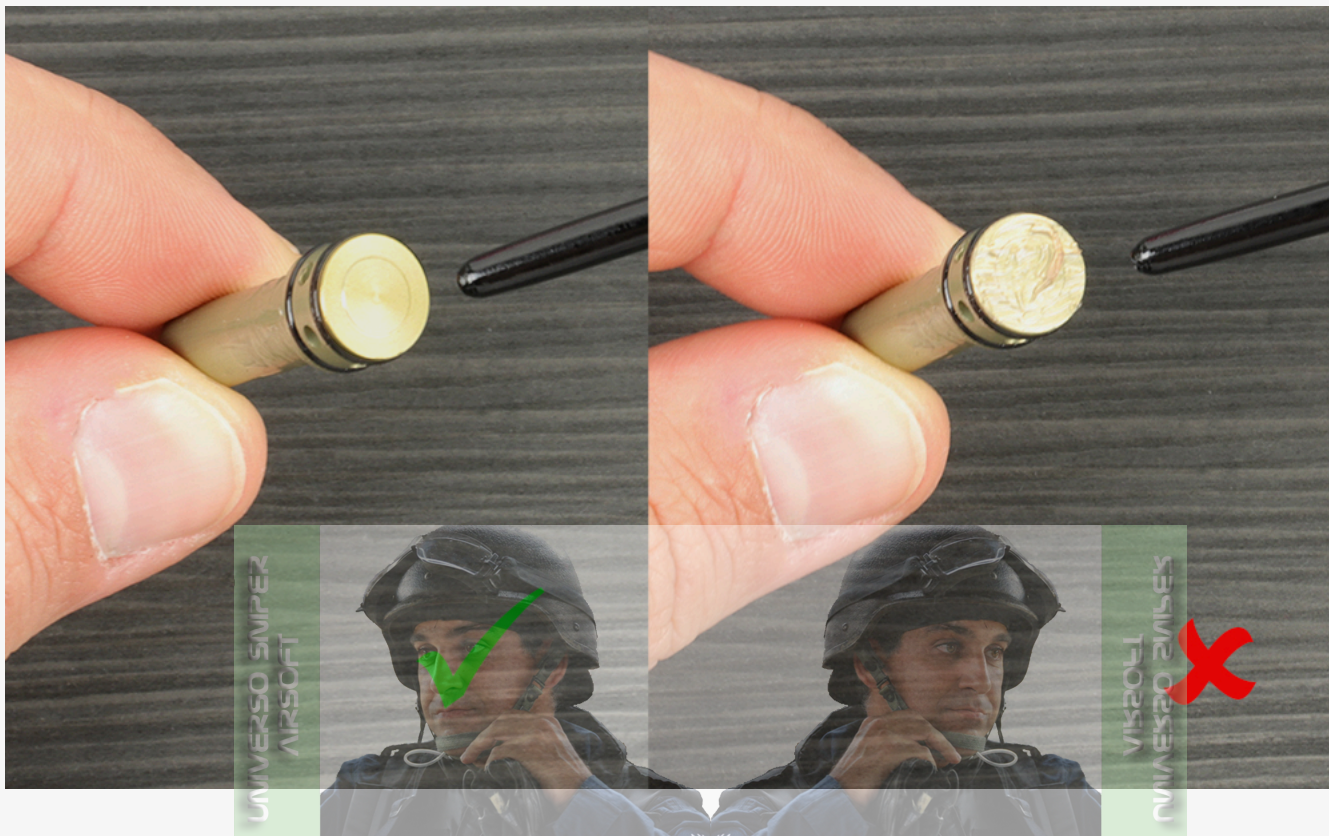

Muzzle Velocity [FPS] depending on Pressure [PSI]

Below are the muzzle velocities obtained depending on the pressure set, measured with 200 mm, 300 mm , and 500 mm barrels. Measurements were carried out with BBs on weighing – **0.25 g**.

200 mm Barrel

Pressure [PSI]	Muzzle Velocity [FPS]
60	250
70	268
80	285
90	300
100	319
110	328
120	347

300 mm Barrel

Pressure [PSI]	Muzzle Velocity [FPS]
----------------	-----------------------

60	210
70	270
80	294
90	310
100	327
110	339
120	354

500 mm Barrel

Pressure [PSI]	Muzzle Velocity [FPS]
60	230
70	318
80	348
90	370
100	389
110	404
120	430

[User Manual – TITAN II Bluetooth® EXPERT for V2 GB \[HPA\]](#)

[User Manual – ASTER II Bluetooth® EXPERT for V2 GB \[AEG & HPA\]](#)

[User Manual – ASTER II Bluetooth® EXPERT for V3 GB \[AEG & HPA\]](#)

Technical Specifications

The design and production of the device is based on harmonized standards.

Solenoid Voltage Range	5-8.4 V
Operating Pressure	60-140 PSI – high pressure only
Gas Consumption	For 90 PSI and a 48 ci/0.8 l 300 bar/4500 PSI bottle – 1 PSI per shot
Dimensions (Length x Diameter)	88 mm x 25.4 mm
Finished Product Weight	75 g
Operating Temperature Range	min. -15° C, max. +50° C
Relative Humidity	≤ 80%

Legal Notice

Exclusion of Liability

GATE Enterprise sp. z o.o. sp. k. is not liable for any damages, injuries or accidents of any kind resulting from the use of this product or airsoft gun with the product installed, including (but not limited to) incidental or special damages to airsoft gun, airsoft gun parts and batteries.

Disclaimer

GATE Enterprise sp. z o.o. sp. k. takes no responsibility regarding compliance of the product with the requirements of any law, rule or airsoft restrictions pertaining thereto.

Intellectual Property

Intellectual Property owned by GATE Enterprise sp. z o.o. sp. k., including (but not limited to) devices, accessories, parts, software, documentation, is proprietary to GATE Enterprise sp. z o.o. sp. k. and protected under Polish laws, EU laws and international treaty provisions. You may not violate the rights of the Intellectual Property and you will not prepare derivative works of or reverse engineer the device or software. No ownership in the Intellectual Property is transferred to you.

GATE Limited Warranty Policy

GATE Enterprise sp. z o.o. sp. k. warrants that its Product is free from manufacturing and material defects at the date of purchase and for a period of two (2) years from the date of purchase and it is nonextendable. This Limited Warranty is conditioned upon proper use of Product by Purchaser.

1. This Limited Warranty is valid provided that the owner provides a proof of purchase and properly completed warranty form.
2. This Limited Warranty does not cover: (a) defects or damage (e.g. mechanical, thermal or chemical) resulting from accident, misuse (misinterpretation of the instructions), abuse, neglect, unusual physical, electrical or electromechanical stress, water immersion, repairs or structural modification of any part of Product, or (b) the Product that has its serial number removed or made illegible; (c) defects or damage from improper operation, maintenance or installation, (d) installation of the products.
3. Requests for warranty are processed as soon as possible, not exceeding seven (7) working days. The company's obligation under this Limited Warranty shall be limited to providing replacement of parts only.



Note

The product warranty form is available here: <http://www.gatee.eu/warranty>.

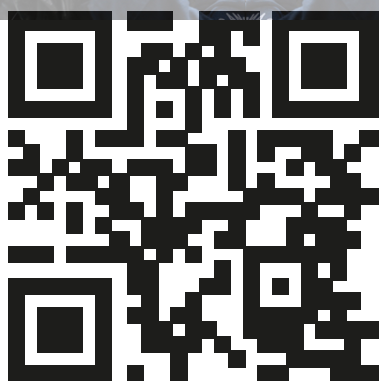

Product Disposal Instructions

The symbol shown here means that the product is classified as Electrical or Electronic Equipment and should not be disposed with other household and commercial waste at the end of its working life. The Waste of Electrical and Electronic Equipment (WEEE Directive 2012/19/EU) has been put in place to recycle products using best available recovery and recycling techniques to minimize the impact on the environment. Purchasers shall take any old electrical equipment to waste recycling public centres or points of sale.



Product Compliance

Declaration of Conformity

GATE Enterprise sp. z o.o. sp. k. hereby declares under its sole responsibility that PULSAR H HPA Engine is in conformity with the essential requirements of the following directive: 2011/65/UE.



Stay tuned with GATE

 GATE Enterprise

<http://help.gatee.eu>

Join the GATE Airsoft Community [Discord Server!](#)

 Error

 GateMovies

 Instagram



Manufactured by GATE Enterprise sp. z o.o. sp. k.

Torowa 3H

PL-30435 KRAKÓW

email: support@gatee.eu

tel: +48 12 210 05 23

 Aún no le ha gustado a nadie