

CARBON BARREL EXTENSIONS

SBA-CBX-01/02/03/04/05

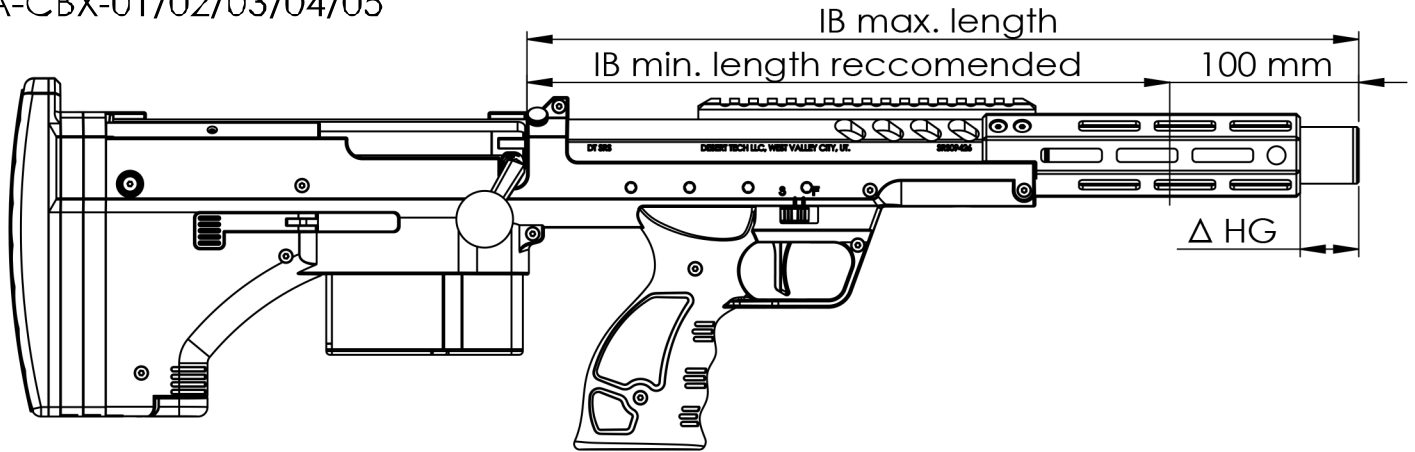

1) mounting options

These Carbon barrel extensions are designed to be mounted directly on G-Spec barrels (SRS A1 & A2) & TAC-41 barrel base. You can also directly mount these extensions on Sport barrels (16'' & 20''), and TAC-41 barrels. Finally, if you're willing to mount these extensions on any other barrels, you will have to use a DT muzzle brake (please check references SBA-FHD-06 & SBA-FHD-07), and a set of timing shims (please check reference SBA-SIL-06). To properly time the muzzle brake, please refer the Youtube video by following the QR code bellow.

2) Inner barrel length

Please refer to the chart next page to know the maximum inner barrel length of your personal configuration. For concentricity reasons, we suggest you also to respect a minimum inner barrel length (100 mm shorter than the maximum length). Your carbon barrel extension is delivered with barrel spacer(s) (1 piece for the XS model, 2 pieces for S/M/L models, and 3 pieces for the XL model). Place one barrel spacer at the inner-barrel muzzle extremity, and if necessary, distribute the others on the protruding inner barrel. Additional barrel spacers can be purchased separately (please check reference SBA-BBS-11).

3) Muzzle-Handguard/Stock/Rail offset

Please refer the chart next page to know the distance between the carbon barrel extension muzzle and the front face of the handguard/stock/rail. If the distance is negative, that means the carbon barrel extension muzzle will sit inside the handguard/stock/rail.

4) Integral silencer use

It is possible to use your carbon barrel extension as integrally suppressed barrel by using up to 100 mm (suggested) of foam filling on the muzzle side of your carbon barrel extension. Please check the reference SBA-SIL-18 for additional information.

5) Warnings

Filling the carbon barrel extension with foam may not be legal in your country: users should obey to the law regarding usage and ownership of sound suppressor devices. Using an inner barrel shorter than suggested length may generate concentricity issues at the muzzle. Carbon fiber tubes are prone to get scratched easily, or even broken by impacts. This product requires extra care from the user, specifically for the longer versions. Due to the manufacturing process, all tubes present an overlap pattern, and may not be exempt of small visual defects.



SBA-SIL-18



SBA-SIL-06



YOUTUBE tutorial



SBA-FHD-06



SBA-FHD-07



SBA-BBS-11

BARREL	EXTENSION	IB MAX	IB MIN recommended	A2		A1		
				Δ HG Covert	Δ HG Long	Δ HG Covert	Δ HG M-Lok	Δ HG Long
G-Spec A2	XS	434 mm	334 mm	31 mm	-123 mm	Not compatible.		
	S	509 mm	409 mm	106 mm	-48 mm			
	M	584 mm	484 mm	181 mm	27 mm			
	L	659 mm	559 mm	256 mm	102 mm			
	XL	734 mm	634 mm	331 mm	177 mm			
G-Spec A1	XS	460 mm	360 mm	57 mm	-98 mm	59 mm	9 mm	-102 mm
	S	535 mm	435 mm	132 mm	-23 mm	134 mm	84 mm	-27 mm
	M	610 mm	510 mm	207 mm	53 mm	209 mm	159 mm	49 mm
	L	685 mm	585 mm	282 mm	128 mm	284 mm	234 mm	124 mm
	XL	760 mm	660 mm	357 mm	203 mm	359 mm	309 mm	199 mm
G-Spec A2 + extension	XS	465 mm	365 mm	62 mm	-92 mm	64 mm	14 mm	-96 mm
	S	540 mm	440 mm	137 mm	-17 mm	139 mm	89 mm	-21 mm
	M	615 mm	515 mm	212 mm	58 mm	214 mm	164 mm	54 mm
	L	690 mm	590 mm	287 mm	133 mm	289 mm	239 mm	129 mm
	XL	765 mm	665 mm	362 mm	208 mm	364 mm	314 mm	204 mm
16" + DT muzzle brake	XS	573 mm	473 mm	170 mm	16 mm	172 mm	122 mm	12 mm
	S	648 mm	548 mm	245 mm	91 mm	247 mm	197 mm	87 mm
	M	723 mm	623 mm	320 mm	166 mm	322 mm	272 mm	162 mm
	L	798 mm	698 mm	395 mm	241 mm	397 mm	347 mm	237 mm
	XL	873 mm	773 mm	470 mm	316 mm	472 mm	422 mm	312 mm
16" Sport	XS	577 mm	477 mm	174 mm	20 mm	176 mm	126 mm	16 mm
	S	652 mm	552 mm	249 mm	95 mm	251 mm	201 mm	91 mm
	M	727 mm	627 mm	324 mm	170 mm	326 mm	276 mm	166 mm
	L	802 mm	702 mm	399 mm	245 mm	401 mm	351 mm	241 mm
	XL	877 mm	777 mm	474 mm	320 mm	476 mm	426 mm	316 mm
18" + DT muzzle brake	XS	624 mm	524 mm	221 mm	67 mm	223 mm	173 mm	63 mm
	S	699 mm	599 mm	296 mm	142 mm	298 mm	248 mm	138 mm
	M	774 mm	674 mm	371 mm	217 mm	373 mm	323 mm	213 mm
	L	849 mm	749 mm	446 mm	292 mm	448 mm	398 mm	288 mm
	XL	924 mm	824 mm	521 mm	367 mm	523 mm	473 mm	363 mm
20" Sport	XS	656 mm	556 mm	253 mm	99 mm	255 mm	205 mm	95 mm
	S	731 mm	631 mm	328 mm	174 mm	330 mm	280 mm	170 mm
	M	806 mm	706 mm	403 mm	249 mm	405 mm	355 mm	245 mm
	L	881 mm	781 mm	478 mm	324 mm	480 mm	430 mm	320 mm
	XL	956 mm	856 mm	553 mm	399 mm	555 mm	505 mm	395 mm
22" + DT muzzle brake	XS	732 mm	632 mm	329 mm	175 mm	331 mm	281 mm	171 mm
	S	807 mm	707 mm	404 mm	250 mm	406 mm	356 mm	246 mm
	M	882 mm	782 mm	479 mm	325 mm	481 mm	431 mm	321 mm
	L	957 mm	857 mm	554 mm	400 mm	556 mm	506 mm	396 mm
	XL	1032 mm	932 mm	629 mm	475 mm	631 mm	581 mm	471 mm
25" + DT muzzle brake	XS	804 mm	704 mm	401 mm	247 mm	403 mm	353 mm	243 mm
	S	879 mm	779 mm	476 mm	322 mm	478 mm	428 mm	318 mm
	M	954 mm	854 mm	551 mm	397 mm	553 mm	503 mm	393 mm
	L	1029 mm	929 mm	626 mm	472 mm	628 mm	578 mm	468 mm
	XL	1104 mm	1004 mm	701 mm	547 mm	703 mm	653 mm	543 mm
26" + DT muzzle brake	XS	834 mm	734 mm	431 mm	277 mm	433 mm	383 mm	273 mm
	S	909 mm	809 mm	506 mm	352 mm	508 mm	458 mm	348 mm
	M	984 mm	884 mm	581 mm	427 mm	583 mm	533 mm	423 mm
	L	1059 mm	959 mm	656 mm	502 mm	658 mm	608 mm	498 mm
	XL	1134 mm	1034 mm	731 mm	577 mm	733 mm	683 mm	573 mm

BARREL	EXTENSION	IB MAX	IB MIN recommended	TAC 4/P		TAC 4/A	
				Δ Stock	Δ Long Rail	Δ Stock	Δ Handguard
Barrel base (AEG hopup)	XS	199 mm	99 mm	-15 mm	-52 mm	84 mm	-111 mm
	S	274 mm	174 mm	60 mm	23 mm	159 mm	-36 mm
	M	349 mm	249 mm	135 mm	98 mm	234 mm	40 mm
	L	424 mm	324 mm	210 mm	173 mm	309 mm	115 mm
	XL	499 mm	399 mm	285 mm	248 mm	384 mm	190 mm
330 (AEG hopup)	XS	478 mm	378 mm	264 mm	226 mm	84 mm	168 mm
	S	553 mm	453 mm	339 mm	301 mm	159 mm	243 mm
	M	628 mm	528 mm	414 mm	376 mm	234 mm	318 mm
	L	703 mm	603 mm	489 mm	451 mm	309 mm	393 mm
	XL	778 mm	678 mm	564 mm	526 mm	384 mm	468 mm
420 (AEG hopup)	XS	568 mm	468 mm	354 mm	316 mm	452 mm	258 mm
	S	643 mm	543 mm	429 mm	391 mm	527 mm	333 mm
	M	718 mm	618 mm	504 mm	466 mm	602 mm	408 mm
	L	793 mm	693 mm	579 mm	541 mm	677 mm	483 mm
	XL	868 mm	768 mm	654 mm	616 mm	752 mm	558 mm
510 (AEG hopup)	XS	658 mm	558 mm	444 mm	406 mm	542 mm	348 mm
	S	733 mm	633 mm	519 mm	481 mm	617 mm	423 mm
	M	808 mm	708 mm	594 mm	556 mm	692 mm	498 mm
	L	883 mm	783 mm	669 mm	631 mm	767 mm	573 mm
	XL	958 mm	858 mm	744 mm	706 mm	842 mm	648 mm
Barrel base (GBB hopup)	XS	196 mm	96 mm	-15 mm	-52 mm	84 mm	-111 mm
	S	271 mm	171 mm	60 mm	23 mm	159 mm	-36 mm
	M	346 mm	246 mm	135 mm	98 mm	234 mm	40 mm
	L	421 mm	321 mm	210 mm	173 mm	309 mm	115 mm
	XL	496 mm	396 mm	285 mm	248 mm	384 mm	190 mm
330 (GBB hopup)	XS	475 mm	375 mm	264 mm	226 mm	84 mm	168 mm
	S	550 mm	450 mm	339 mm	301 mm	159 mm	243 mm
	M	625 mm	525 mm	414 mm	376 mm	234 mm	318 mm
	L	700 mm	600 mm	489 mm	451 mm	309 mm	393 mm
	XL	775 mm	675 mm	564 mm	526 mm	384 mm	468 mm
420 (GBB hopup)	XS	565 mm	465 mm	354 mm	316 mm	452 mm	258 mm
	S	640 mm	540 mm	429 mm	391 mm	527 mm	333 mm
	M	715 mm	615 mm	504 mm	466 mm	602 mm	408 mm
	L	790 mm	690 mm	579 mm	541 mm	677 mm	483 mm
	XL	865 mm	765 mm	654 mm	616 mm	752 mm	558 mm
510 (GBB hopup)	XS	655 mm	555 mm	444 mm	406 mm	542 mm	348 mm
	S	730 mm	630 mm	519 mm	481 mm	617 mm	423 mm
	M	805 mm	705 mm	594 mm	556 mm	692 mm	498 mm
	L	880 mm	780 mm	669 mm	631 mm	767 mm	573 mm
	XL	955 mm	855 mm	744 mm	706 mm	842 mm	648 mm