

MDRX

V3 16"

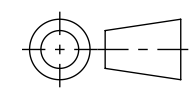

PART #	DESCRIPTION	QTY
MDR-0100-04	7.62 UPPER RECEIVER	1
MDR-0200-03	7.62 LOWER RECEIVER	1
MDR-1900-04	7.62 MAGAZINE	1
MDR-1300-02	16 BARREL	1
MDR-1500-02	MICRON HANDGUARD	1
MDR-1400-01	BUTTPLATE	1

ASSEMBLY #:	MDR-0000-01	DATE:	2024/04/05	SILVERBACK AIRSOFT
ASSEMBLY NAME:	MDRX 16"			
		SCALE: 1:2	SHEET 1 OF 14	A3

MDR X

V3 MICRON

PART #	DESCRIPTION	QTY
MDR-0100-04	5.56 UPPER RECEIVER	1
MDR-0200-03	5.56 LOWER RECEIVER	1
MDR-1900-04	5.56 MAGAZINE	1
MDR-1300-04	10.5 BARREL	1
MDR-1500-02	MICRON HANDGUARD	1
MDR-1400-01	BUTTPLATE	1

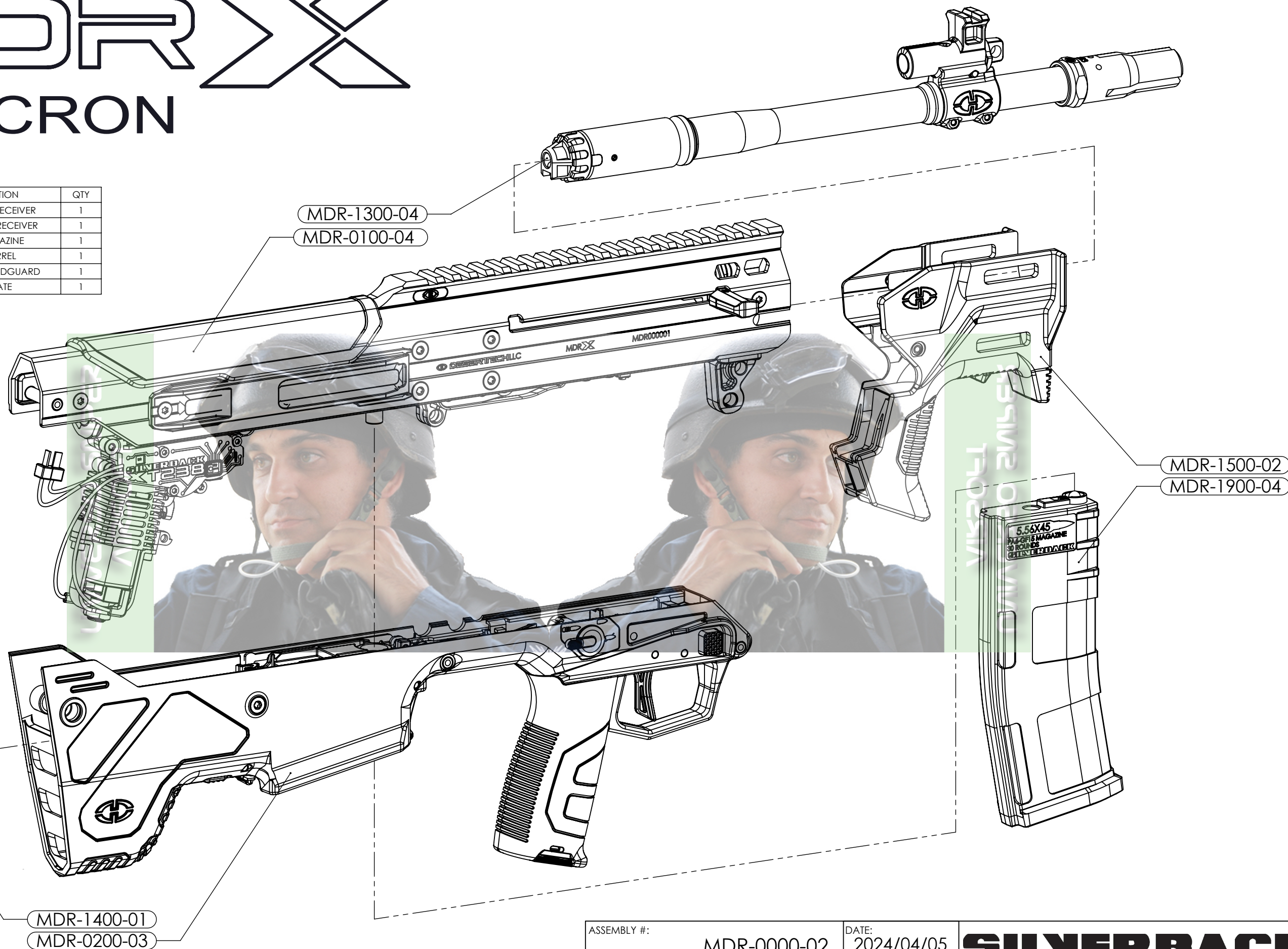

ASSEMBLY #: MDR-0000-02
 ASSEMBLY NAME: MDRX MICRON

DATE: 2024/04/05

SILVERBACK AIRSOFT

SCALE: 1:2 SHEET 2 OF 14 A3

MDR-0100-03

7.62 UPPER RECEIVER

PART #	DESCRIPTION	QTY
MDR-0100-02-X	UPPER RECEIVER WITH GB.	1
MDR-0103	FEEDING TUBE	1

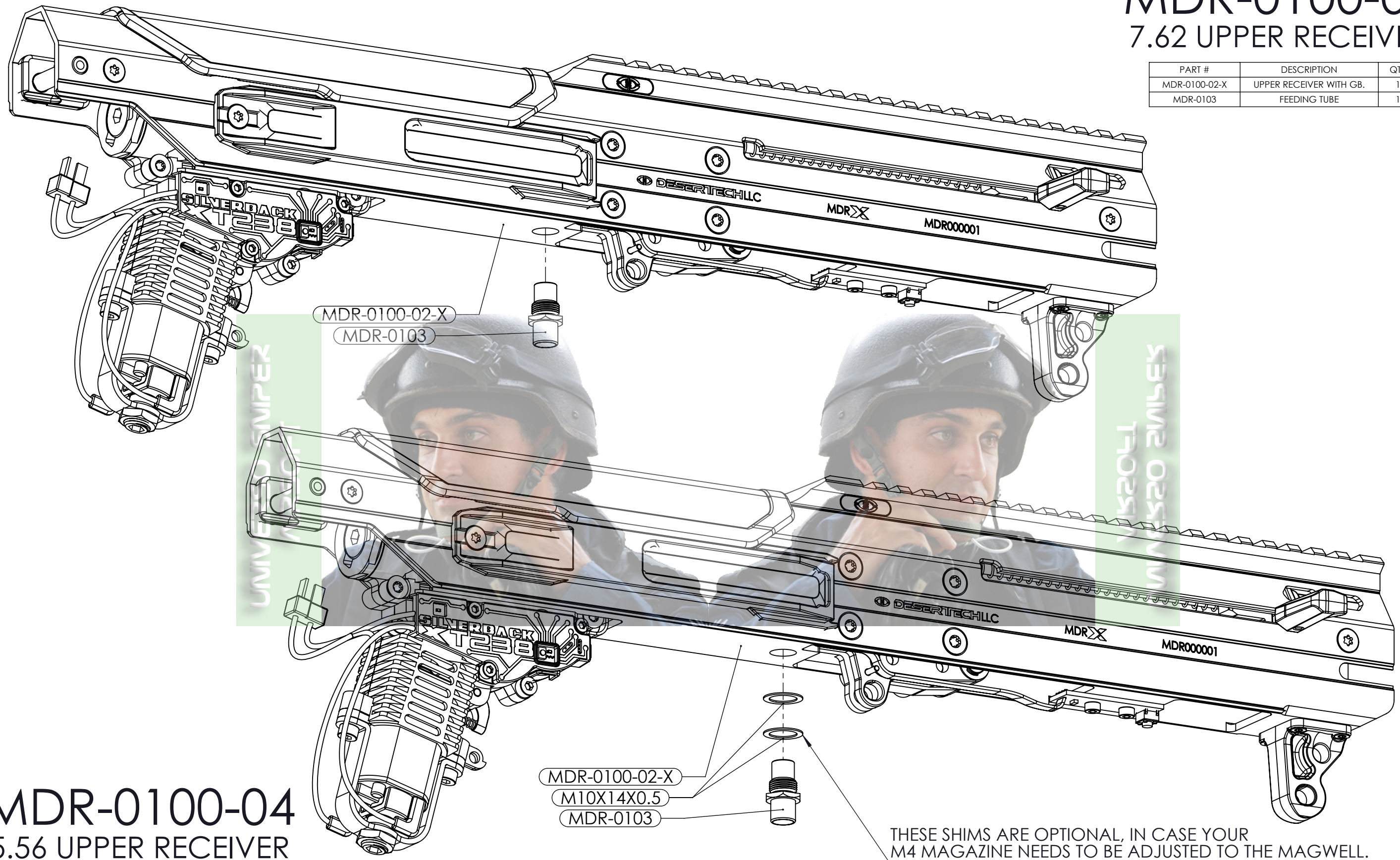

MDR-0100-04

5.56 UPPER RECEIVER

PART #	DESCRIPTION	QTY
MDR-0100-02	UPPER RECEIVER WITH GB.	1
MDR-0103	FEEDING TUBE	1
M10X14X0.5	SHIM	0-2

MDR-0100-02-X
M10X14X0.5
MDR-0103

THESE SHIMS ARE OPTIONAL, IN CASE YOUR M4 MAGAZINE NEEDS TO BE ADJUSTED TO THE MAGWELL.

ASSEMBLY #:	MDR-0100-03/04	DATE:	2024/04/05
ASSEMBLY NAME:	7.62/5.56 UPPER RECEIVER		

SILVERBACK AIRSOFT

8 7 6 5 4 3 2 1

F

F

E

E

D

D

C

C

B

B

A

A

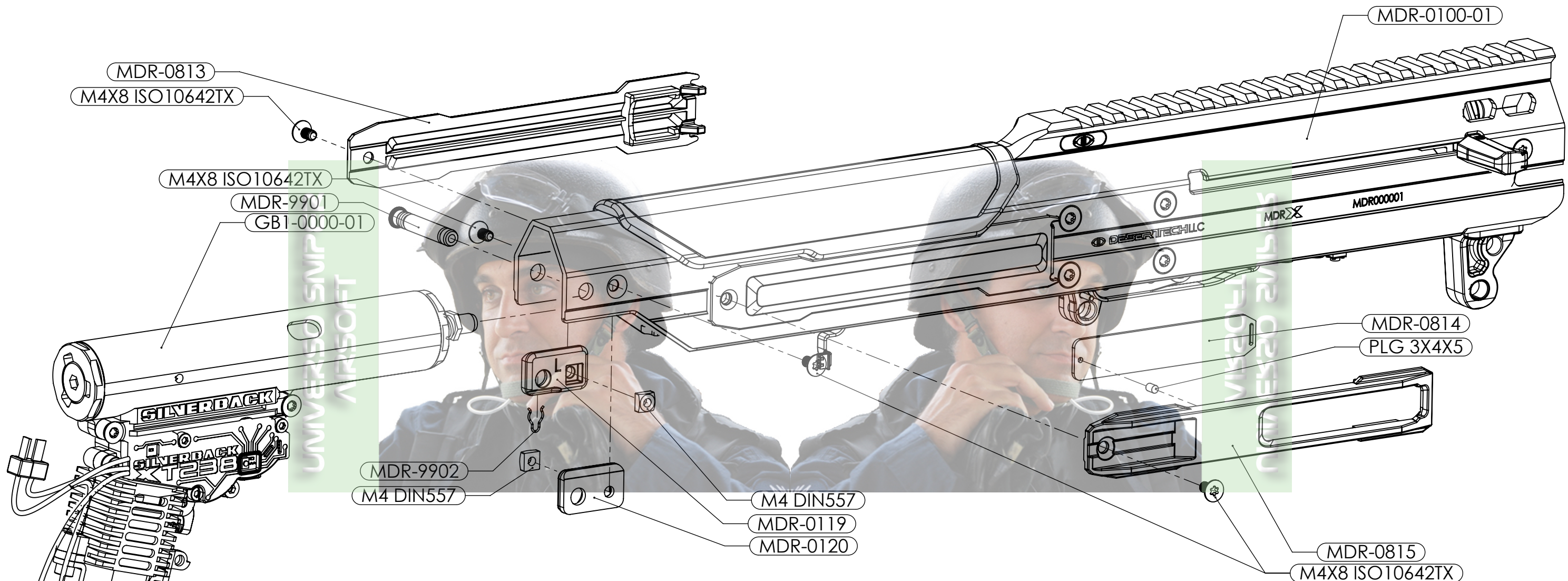

PART #	DESCRIPTION	QTY
MDR-0100-01	UPPER RECEIVER w/o GEARBOX	1
GB1-0000-01	75% CYLINDER GEARBOX	1
MDR-0119	ASSEMBLY PIN HOLDER LEFT	1
MDR-0120	ASSEMBLY PIN HOLDER RIGHT	1
MDR-9901	ASSEMBLY PIN	1
MDR-9902	ASSEMBLY PIN LOCK	1
M4X8 ISO10642TX	SCREW	4
M4 DIN557	NUT	2
MDR-0813	SE COVER	2
MDR-0814	SE DUST COVER	2
MDR-0815	SE EJECTION	2
PLG 3X4X5	BALL PLUNGER	2

ASSEMBLY #: MDR-0100-02	DATE: 2024/04/05	
ASSEMBLY NAME: UPPER RECEIVER W/ GEARBOX		
SCALE:2:3		SHEET 4 OF 14
		A3

8 7 6 5 4 3 2 1

8 7 6 5 4 3 2 1

F

F

E

E

D

D

C

C

B

B

A

A

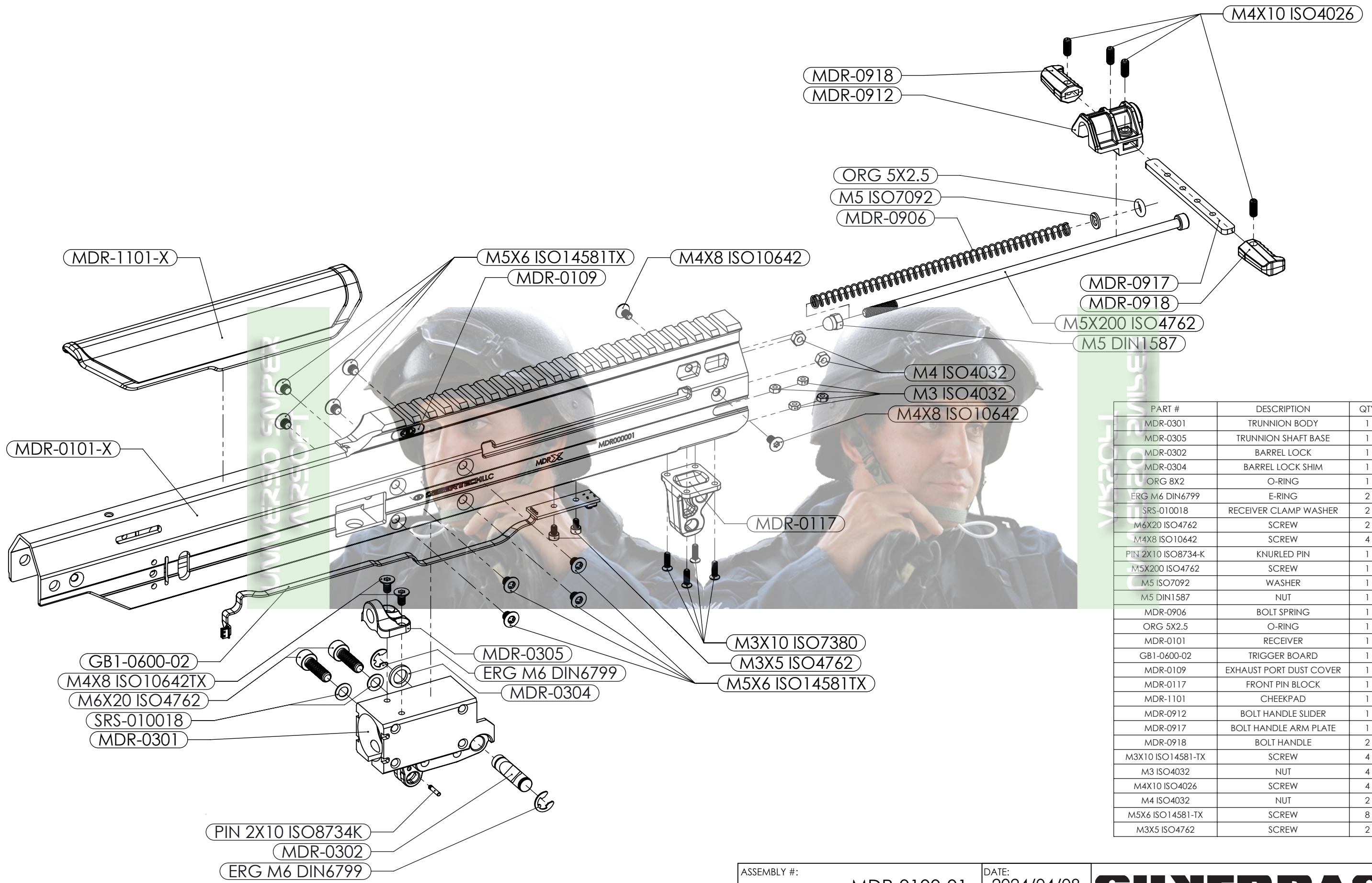

PART #	DESCRIPTION	QTY
MDR-0301	TRUNNION BODY	1
MDR-0305	TRUNNION SHAFT BASE	1
MDR-0302	BARREL LOCK	1
MDR-0304	BARREL LOCK SHIM	1
ORG 8X2	O-RING	1
ERG M6 DIN6799	E-RING	2
SRS-010018	RECEIVER CLAMP WASHER	2
M6X20 ISO4762	SCREW	2
M4X8 ISO10642	SCREW	4
PIN 2X10 ISO8734-K	KNURLED PIN	1
M5X200 ISO4762	SCREW	1
M5 ISO7092	WASHER	1
M5 DIN1587	NUT	1
MDR-0906	BOLT SPRING	1
ORG 5X2.5	O-RING	1
MDR-0101	RECEIVER	1
GB1-0600-02	TRIGGER BOARD	1
MDR-0109	EXHAUST PORT DUST COVER	1
MDR-0117	FRONT PIN BLOCK	1
MDR-1101	CHEEKPAD	1
MDR-0912	BOLT HANDLE SLIDER	1
MDR-0917	BOLT HANDLE ARM PLATE	1
MDR-0918	BOLT HANDLE	2
M3X10 ISO14581-TX	SCREW	4
M3 ISO4032	NUT	4
M4X10 ISO4026	SCREW	4
M4 ISO4032	NUT	2
M5X6 ISO14581-TX	SCREW	8
M3X5 ISO4762	SCREW	2

ASSEMBLY #:	MDR-0100-01	DATE:	2024/04/08	SILVERBACK AIRSOFT
ASSEMBLY NAME:	RECEIVER WITHOUT GEARBOX			
		SCALE:1:2	SHEET 5 OF 14	A3

8 7 6 5 4 3 2 1

8 7 6 5 4 3 2 1

THIS SKATE CAN BE REPLACED BY:
 - MDR-1205: + 0.20 mm THICKNESS
 - MDR-1207: + 0.40 mm THICKNESS
 - MDR-1209: + 0.60 mm THICKNESS

MDR-1203
 MDR-1201
 MDR-1202

THIS SKATE CAN BE REPLACED BY:
 - MDR-1204: + 0.20 mm THICKNESS
 - MDR-1206: + 0.40 mm THICKNESS
 - MDR-1208: + 0.60 mm THICKNESS

MDR-0714
 MDR-0713

MDR-0712
 MDR-0200-01

MDR-0200-02

7.62 LOWER RECEIVER

PART #	DESCRIPTION	QTY
MDR-0200-01-X	LOWER RECEIVER w/o M.C.	1
MDR-0707	7.62 MAG CATCH	1
MDR-0713	FRONT LINKAGE	1
MDR-0714	BACK LINKAGE	1

MDR-0714
 MDR-0713

MDR-0200-03

5.56 LOWER RECEIVER

PART #	DESCRIPTION	QTY
MDR-0200-01	LOWER RECEIVER w/o M.C.	1
MDR-1201	MAGWELL ADAPTER	1
MDR-1202 or 1204 or 1206 or 1208	LEFT SKATE	1
MDR-1203 or 1205 or 1207 or 1209	RIGHT SKATE	1
MDR-0712	MAGCATCH 5.56	1
MDR-0713	LINKAGE FRONT	1
MDR-0714	LINKAGE BACK	1

YOU CAN ADJUST THE MAGWELL TO YOUR M4 MAGAZINE BY SWAPPING THE RED SKATES.

MDR-0200-01
 MDR-0707

ASSEMBLY #:	MDR-0200-02/03	DATE:	2024/04/05
ASSEMBLY NAME:	7.62/5.56 LOWER RECEIVER		

SILVERBACK
AIRSOFT

SCALE:1:2 SHEET 6 OF 14 A3

8 7 6 5 4 3 2 1

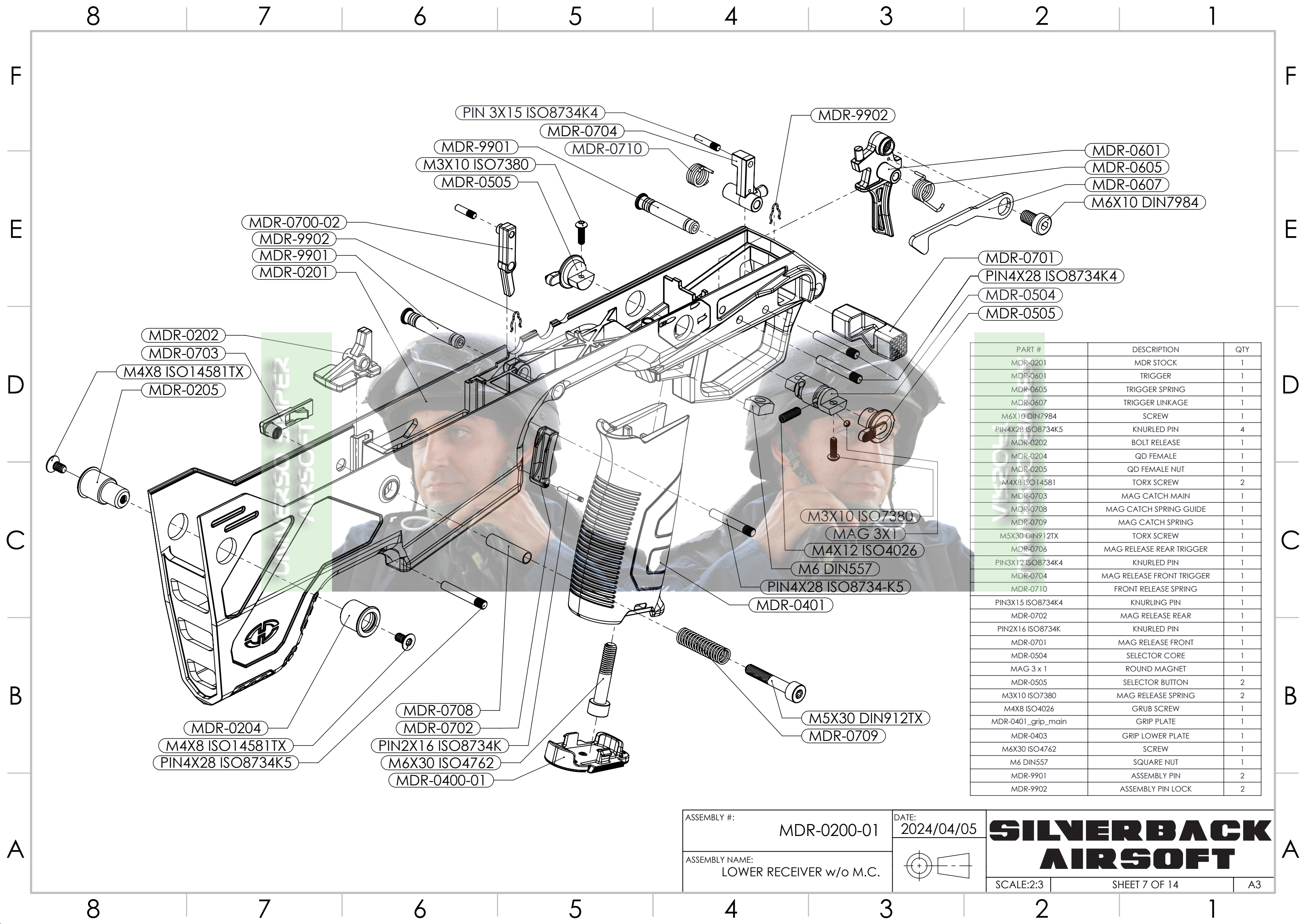

PART #	DESCRIPTION	QTY
MDR-0201	MDR STOCK	1
MDR-0601	TRIGGER	1
MDR-0605	TRIGGER SPRING	1
MDR-0607	TRIGGER LINKAGE	1
M6X10 DIN7984	SCREW	1
PIN4X28 ISO8734K5	KNURLED PIN	4
MDR-0202	BOLT RELEASE	1
MDR-0204	QD FEMALE	1
MDR-0205	QD FEMALE NUT	1
M4X8 ISO14581	TORX SCREW	2
MDR-0703	MAG CATCH MAIN	1
MDR-0708	MAG CATCH SPRING GUIDE	1
MDR-0709	MAG CATCH SPRING	1
M5X30 DIN912TX	TORX SCREW	1
MDR-0706	MAG RELEASE REAR TRIGGER	1
PIN3X12 ISO8734K4	KNURLED PIN	1
MDR-0704	MAG RELEASE FRONT TRIGGER	1
MDR-0710	FRONT RELEASE SPRING	1
PIN3X15 ISO8734K4	KNURLING PIN	1
MDR-0702	MAG RELEASE REAR	1
PIN2X16 ISO8734K	KNURLED PIN	1
MDR-0701	MAG RELEASE FRONT	1
MDR-0504	SELECTOR CORE	1
MAG 3 x 1	ROUND MAGNET	1
MDR-0505	SELECTOR BUTTON	2
M3X10 ISO7380	MAG RELEASE SPRING	2
M4X8 ISO4026	GRUB SCREW	1
MDR-0401_grip_main	GRIP PLATE	1
MDR-0403	GRIP LOWER PLATE	1
M6X30 ISO4762	SCREW	1
M6 DIN557	SQUARE NUT	1
MDR-9901	ASSEMBLY PIN	2
MDR-9902	ASSEMBLY PIN LOCK	2

ASSEMBLY #: MDR-0200-01
 DATE: 2024/04/05
 ASSEMBLY NAME: LOWER RECEIVER w/o M.C.

SILVERBACK AIRSOFT

MDR-1300-02

16" BARREL

PART #	DESCRIPTION	QTE
MDR-1300-01	16 OUTER BARREL	1
M4X5 ISO4027	SCREW	2
MDR-1700-01	420 INNER BARREL + HOPUP	1

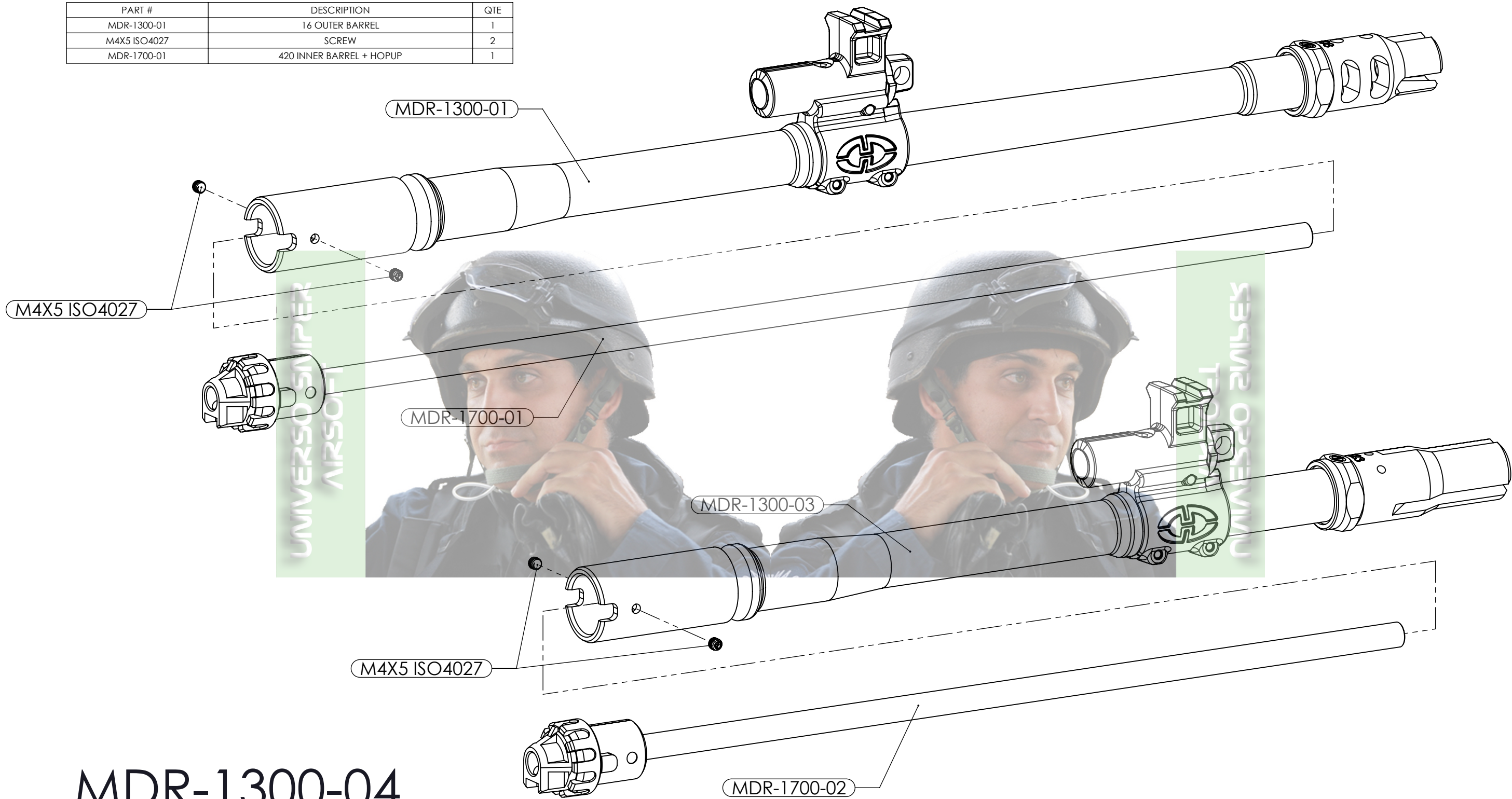

MDR-1300-04

MICRON BARREL

PART #	DESCRIPTION	QTE
MDR-1300-03	10.5 OUTER BARREL	1
MDR-1700-02	330 INNER BARREL + HOPUP	1
M4X5 ISO4027	SCREW	2

ASSEMBLY #:	MDR-1300-02/04	DATE:	2024/04/08
ASSEMBLY NAME:	MDRX MICRON/16" BARREL		

SILVERBACK AIRSOFT

8 7 6 5 4 3 2 1

F
E
D
C
B
A

F
E
D
C
B
A

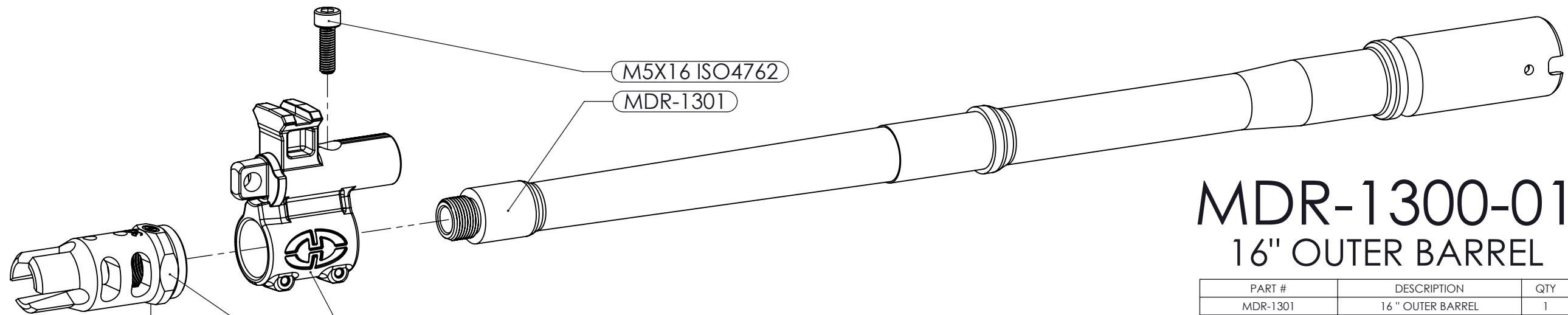

MDR-1300-01

16" OUTER BARREL

PART #	DESCRIPTION	QTY
MDR-1301	16" OUTER BARREL	1
MDR-1313	RATCHET	1
MDR-1601	GAS BLOCK	1
M4X6 ISO4026	SCREW	1
M5X16 ISO4762	SCREW	1



MDR-1300-03

MICRON OUTER BARREL

PART #	DESCRIPTION	QTY
MDR-1303	MICRON OUTER BARREL	1
MDR-1317	RAIDEN FLASH HIDER	1
MDR-1601	GAS BLOCK	1
M4X6 ISO4026	SCREW	1
M5X16 ISO4762	SCREW	1
MDR-1318_MDRX_long_orange_tip		1

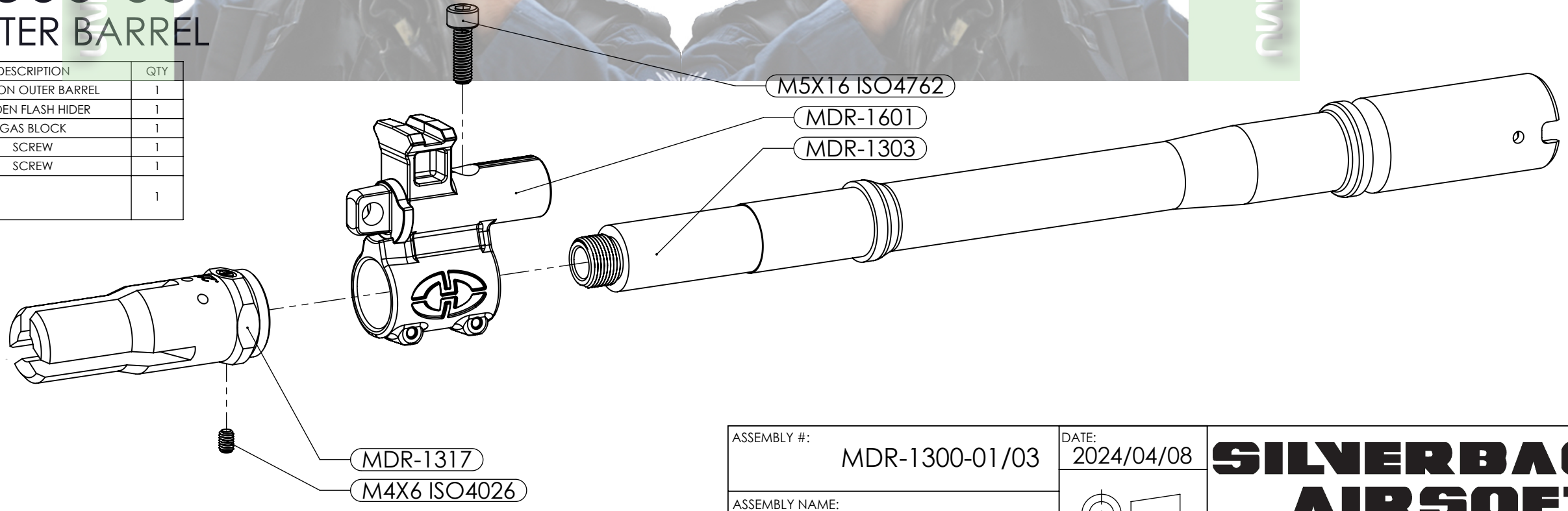

ASSEMBLY #:	MDR-1300-01/03	DATE:	2024/04/08
ASSEMBLY NAME:	16"/MICRON BARREL		

SILVERBACK
AIRSOFT

8 7 6 5 4 3 2 1

8 7 6 5 4 3 2 1

F
E
D
C
B
A

F
E
D
C
B
A

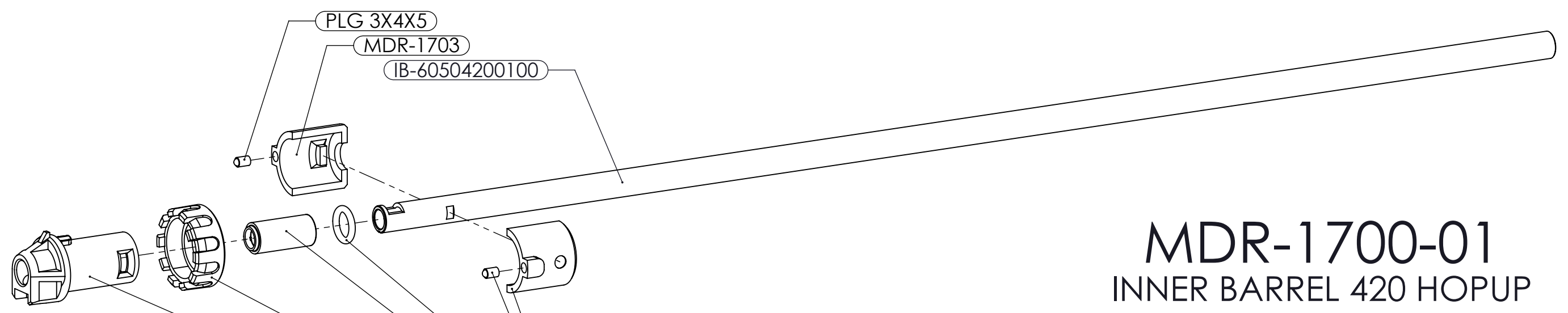

MDR-1700-01 INNER BARREL 420 HOPUP

PART #	DESCRIPTION	QTY
HOP-11702	MDR HOPUP RUBBER 70°	1
IB-60504200100	420 mm AEG INNER BARREL	1
MDR-1701	HOPUP BODY	1
MDR-1703	HOPUP LOCK	2
MDR-1704	HOPUP NUB	1
MDR-1702	HOPUP WHEEL	1
PLG 3X4X5	BALL PLUNGER	2
ORG 8X2	ORING	1

UNIVERSO SNIPER
AIRSOFT

UNIVERSO SNIPER
AIRSOFT

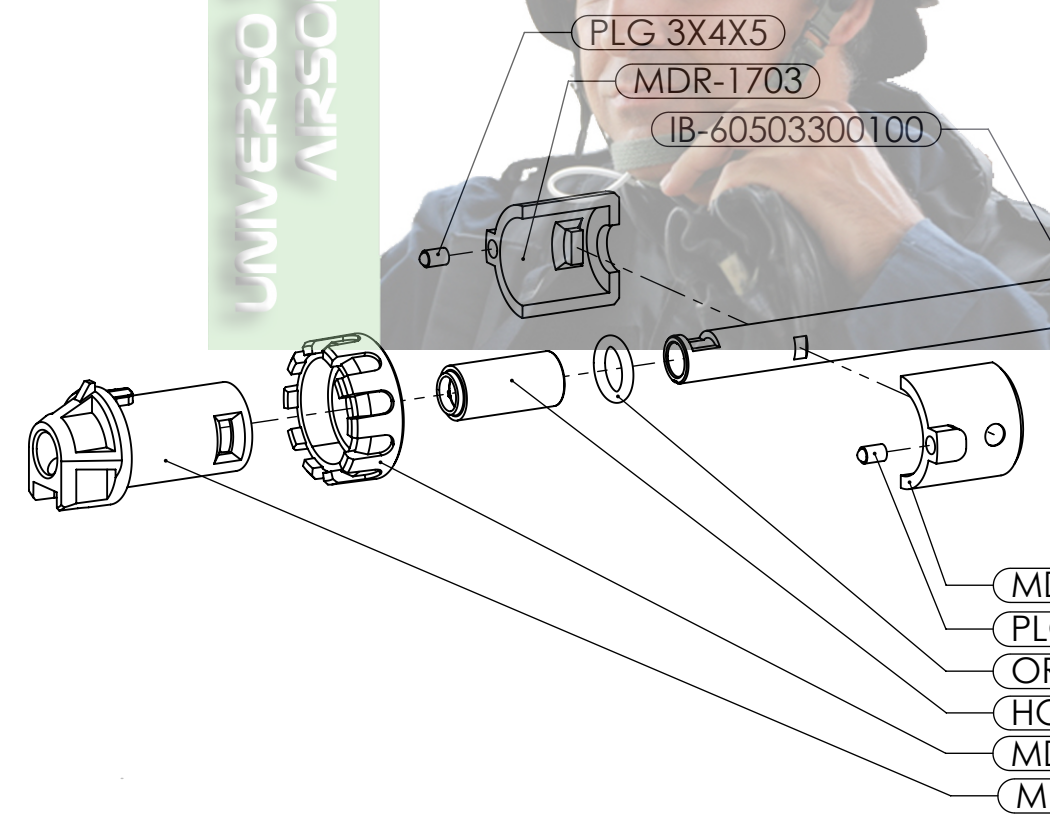
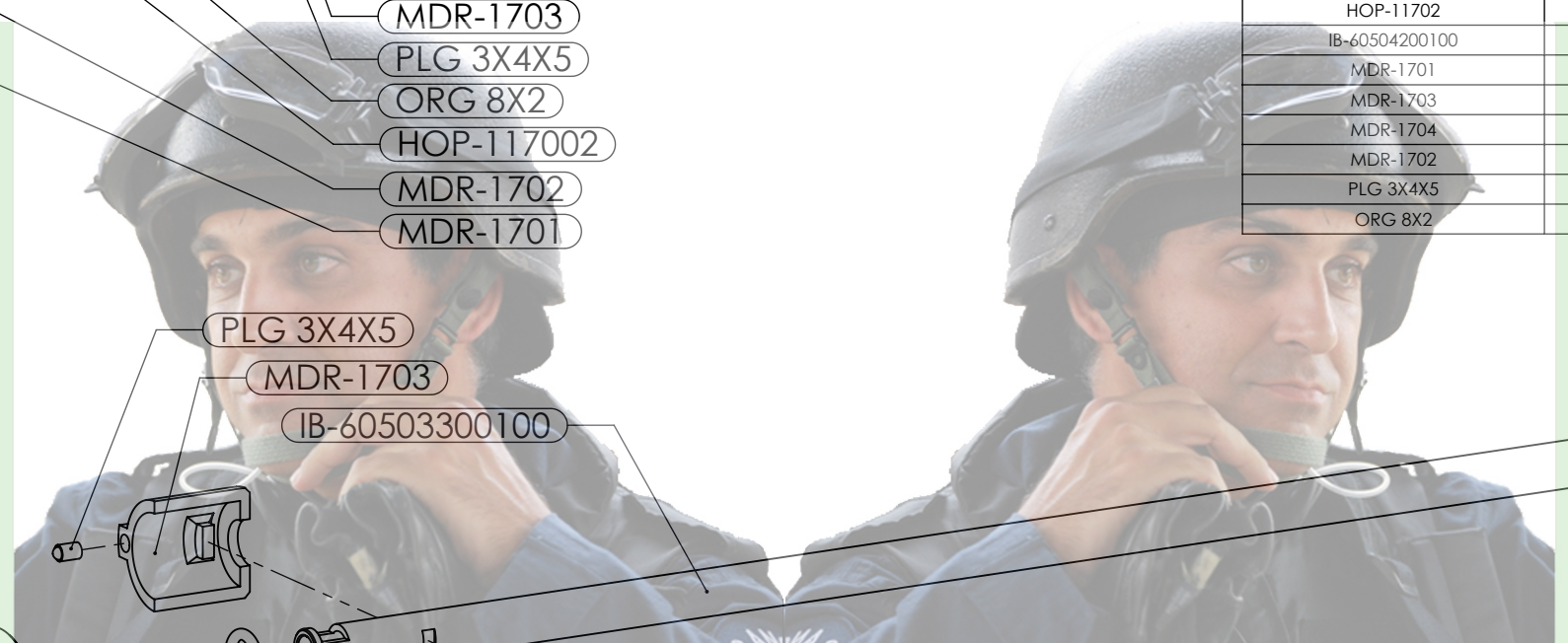

MDR-1700-02 INNER BARREL 330 HOPUP

PART #	DESCRIPTION	QTY
HOP-11702	MDR HOPUP RUBBER 70°	1
IB-60503300100	330 mm AEG INNER BARREL	1
MDR-1701	HOPUP BODY	1
MDR-1703	HOPUP LOCK	2
MDR-1704	HOPUP NUB	1
MDR-1702	HOPUP WHEEL	1
PLG 3X4X5	BALL PLUNGER	1 or 2
ORG 8X2	ORING	1

ASSEMBLY #: MDR-1700-01/02	DATE: 2024/04/08	SILVERBACK AIRSOFT
ASSEMBLY NAME: INNER BARREL + HOPUP		
SCALE:3:4		SHEET 10 OF 14
		A3

8 7 6 5 4 3 2 1

8 7 6 5 4 3 2 1

F

F

E

E

D

D

C

C

B

B

A

A

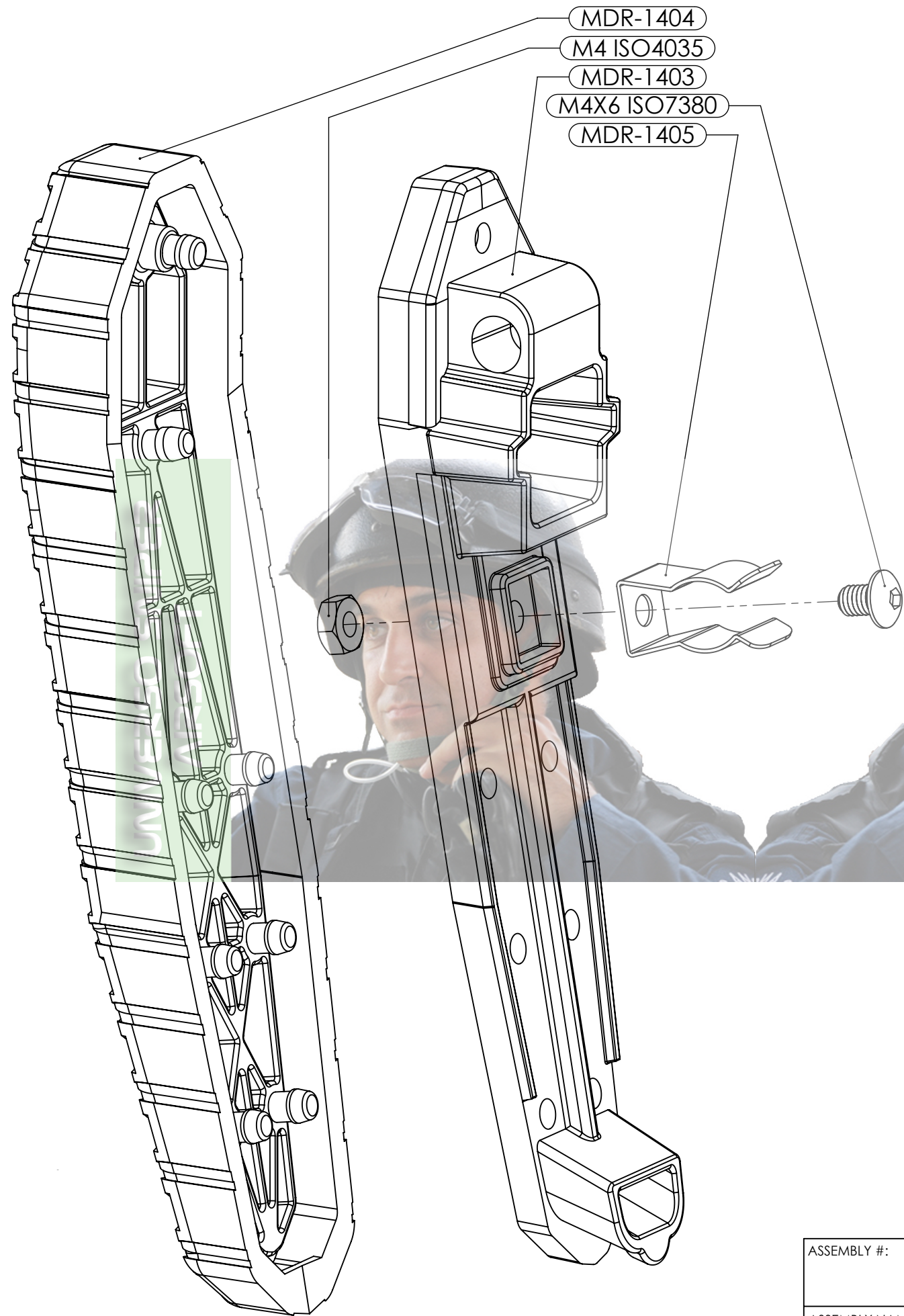

PART #	DESCRIPTION	QTY
MDR-1402	BUTTPLATE BASE	1
M4 ISO4035	NUT	1
M4X6 ISO7380	SCREW	1
MDR-1401	BUTTPLATE DAMPER	1
MDR-1405	QD SPRING CLIP	1

ASSEMBLY #:	MDR-1400-01	DATE:	2024/04/08
ASSEMBLY NAME:	BUTTPLATE		

**SILVERBACK
AIRSOFT**

8 7 6 5 4 3 2 1

8 7 6 5 4 3 2 1

F

F

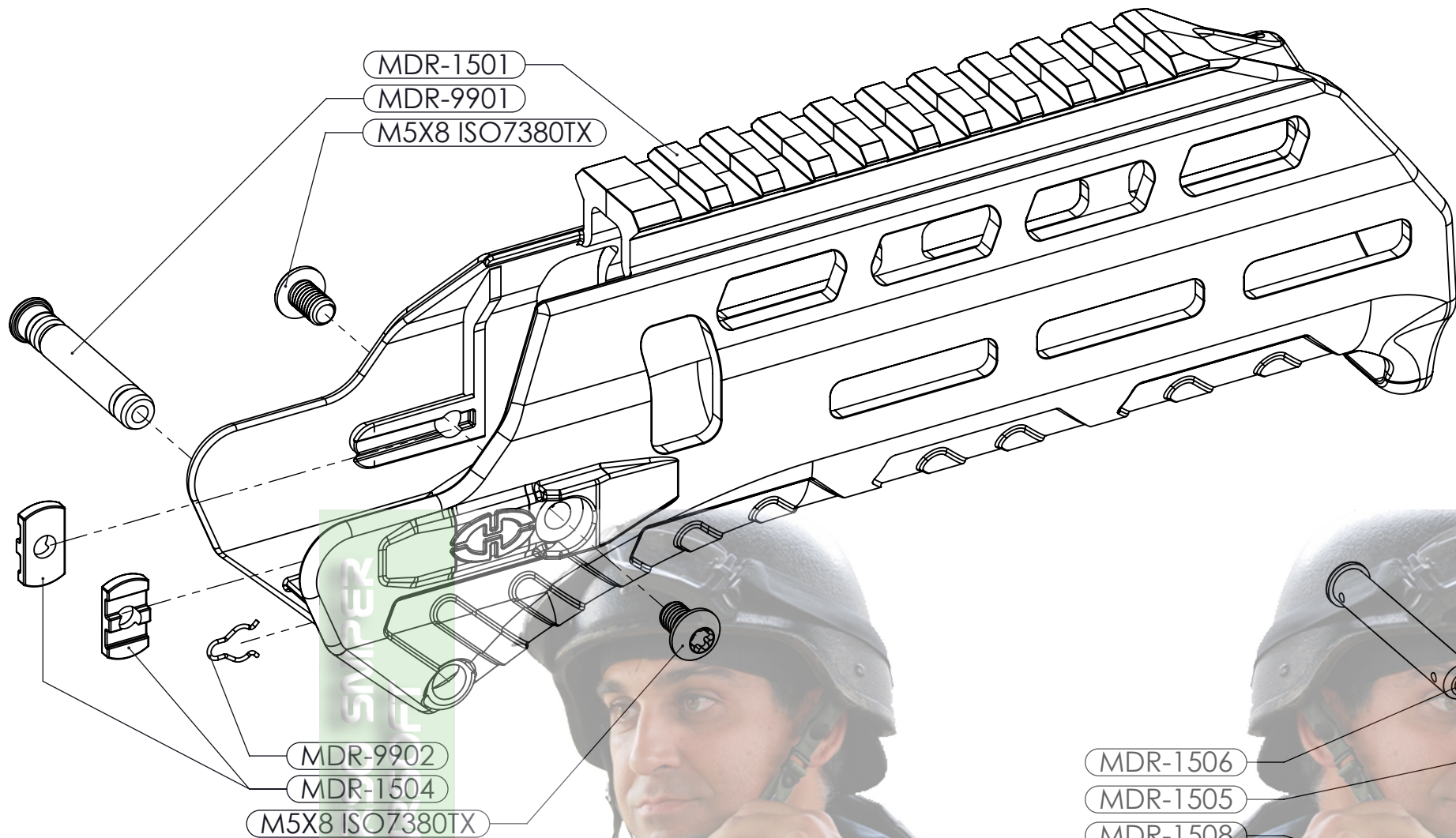

MDR-1500-01

16" HANDGUARD

PART #	DESCRIPTION	QTY
MDR-1501-X	HANDGUARD	1
MDR-1504	HANDGUARD LOCK	2
MDR-9901	ASSEMBLY PIN	1
MDR-9902	ASSEMBLY PIN LOCK	1
M5X8 ISO7380TX	SCREW	2

MDR-1500-02

MICRON HANDGUARD

PART #	DESCRIPTION	QTY
MDR-1505	MICRON HANDGUARD	1
MDR-1506	MICRON H.G. PIN	1
MDR-1508	MICRON H.G. SPRING	1
PIN 2X10 BALL HEAD	BALL HEAD PIN	1
MDR-1509	FOAM STICKER	1

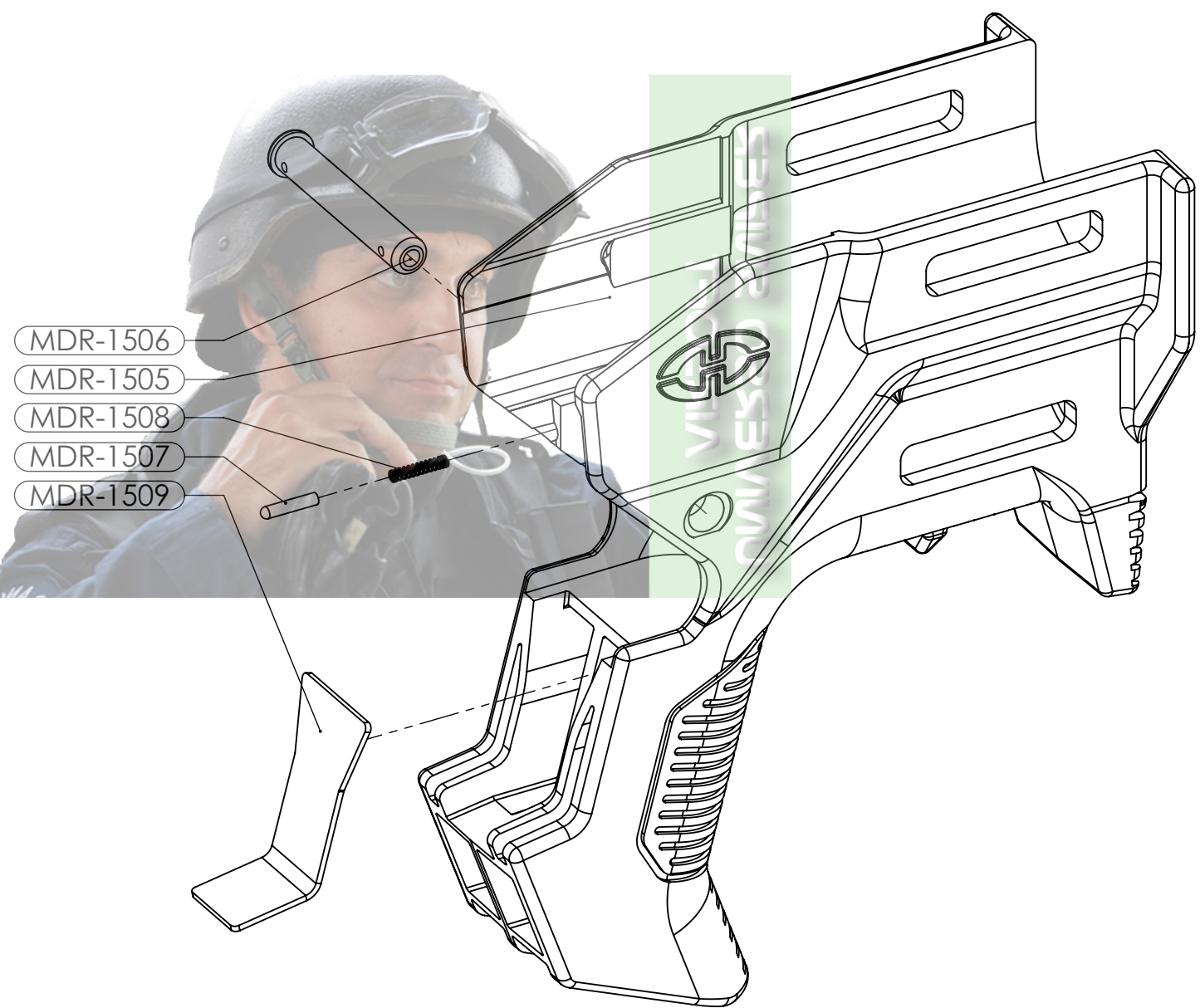

C

C

B

B

A

A

8 7 6 5 4 3 2 1

ASSEMBLY #:
16"/MICRON HANDGUARD

ASSEMBLY NAME:
MDR-1500-01/02

DATE:
2024/04/08

SILVERBACK
AIRSOFT

SCALE:1:1 | SHEET 12 OF 14 | A3

8 7 6 5 4 3 2 1

F
E
D
C
B
A

F
E
D
C
B
A

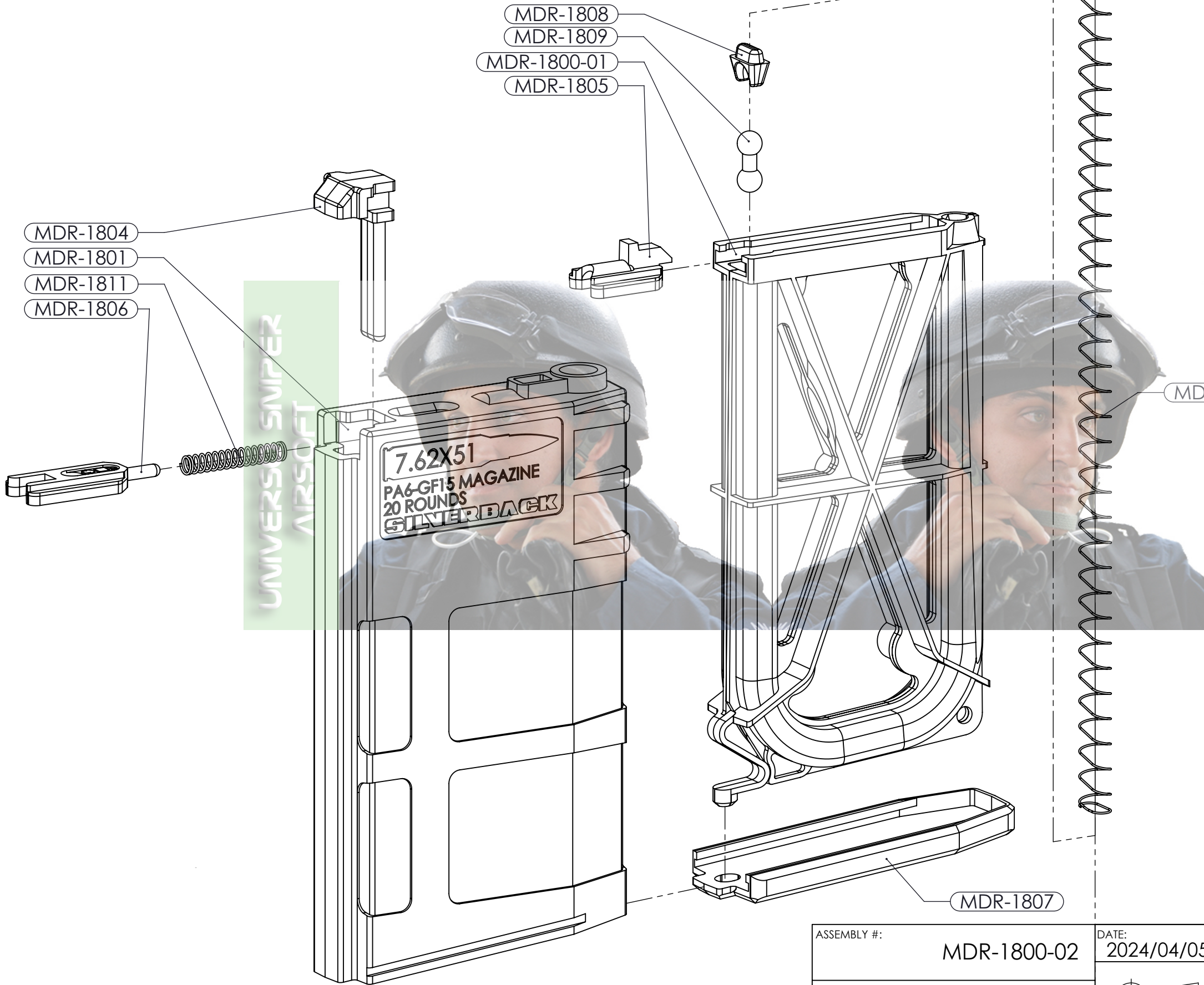

MDR-1804
MDR-1801
MDR-1811
MDR-1806

MDR-1808
MDR-1809
MDR-1800-01
MDR-1805

MDR-1810

MDR-1807

PART #	DESCRIPTION	QTY
MDR-1800-01	MAGAZINE INTERNAL	1
MDR-1801	OUTER SHELL	1
MDR-1804	SPRING GUIDE	1
MDR-1805	BB STOPPER	1
MDR-1806	SPRING GUIDE STOPPER	1
MDR-1807	BOTTOM PLATE	1
MDR-1808	FOLLOWER BASE	1
MDR-1809	FOLLOWER ROD	1
MDR-1811	LOCKER SPRING	1
MDR-1810	FOLLOWER SPRING	1

ASSEMBLY #: MDR-1800-02 DATE: 2024/04/05

ASSEMBLY NAME: 7.62 MIDCAP

SILVERBACK AIRSOFT

8 7 6 5 4 3 2 1

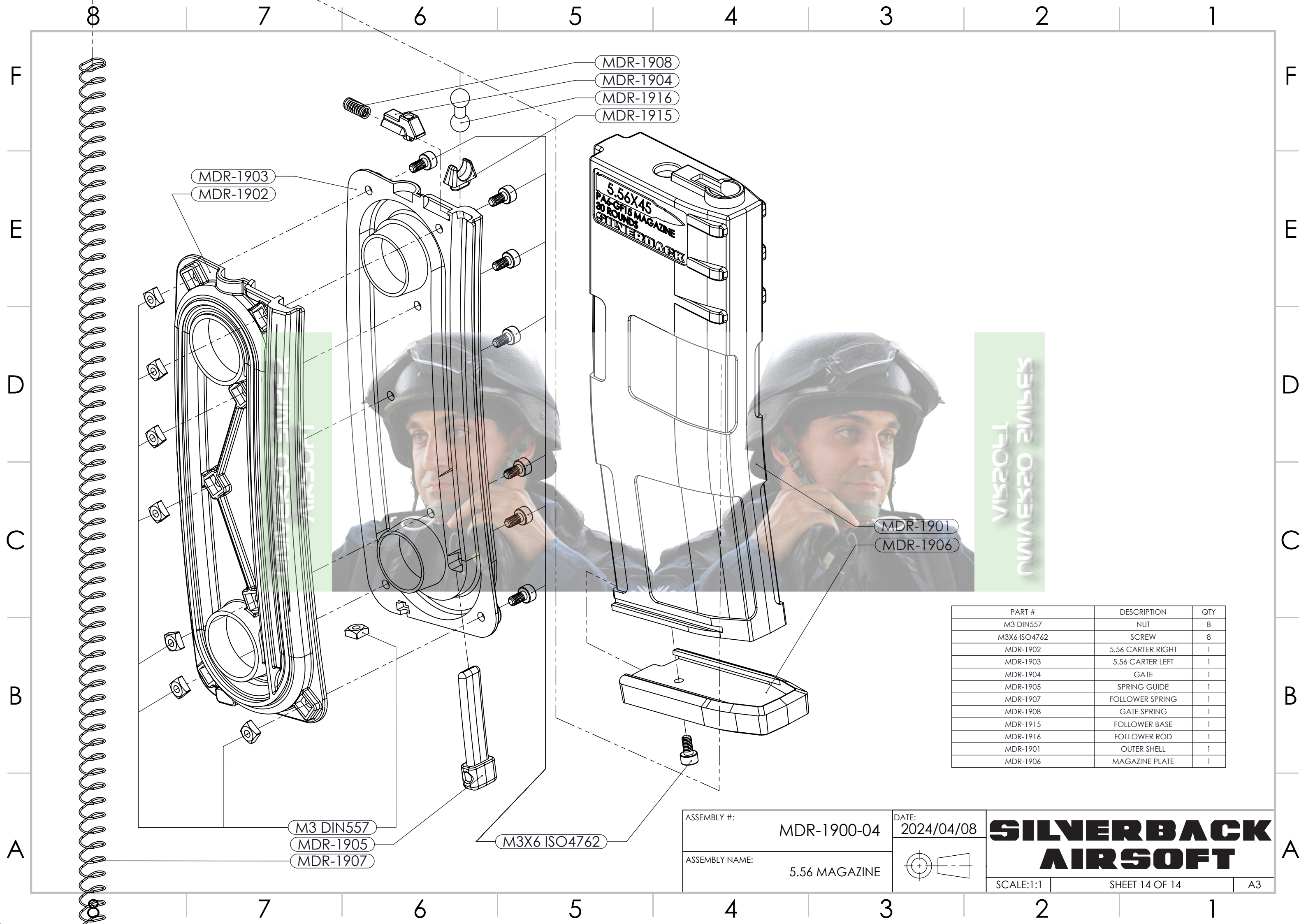

- MDR-1908
- MDR-1904
- MDR-1916
- MDR-1915

- MDR-1903
- MDR-1902

- MDR-1901
- MDR-1906

- M3 DIN557
- MDR-1905
- MDR-1907

M3X6 ISO4762

PART #	DESCRIPTION	QTY
M3 DIN557	NUT	8
M3X6 ISO4762	SCREW	8
MDR-1902	5.56 CARTER RIGHT	1
MDR-1903	5.56 CARTER LEFT	1
MDR-1904	GATE	1
MDR-1905	SPRING GUIDE	1
MDR-1907	FOLLOWER SPRING	1
MDR-1908	GATE SPRING	1
MDR-1915	FOLLOWER BASE	1
MDR-1916	FOLLOWER ROD	1
MDR-1901	OUTER SHELL	1
MDR-1906	MAGAZINE PLATE	1

ASSEMBLY #: MDR-1900-04
 DATE: 2024/04/08
 ASSEMBLY NAME: 5.56 MAGAZINE

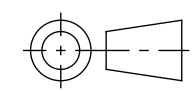

SILVERBACK AIRSOFT